

GUIDE AND CHECKLIST FOR

NONSTRUCTURAL EARTHQUAKE HAZARDS

IN CALIFORNIA SCHOOLS

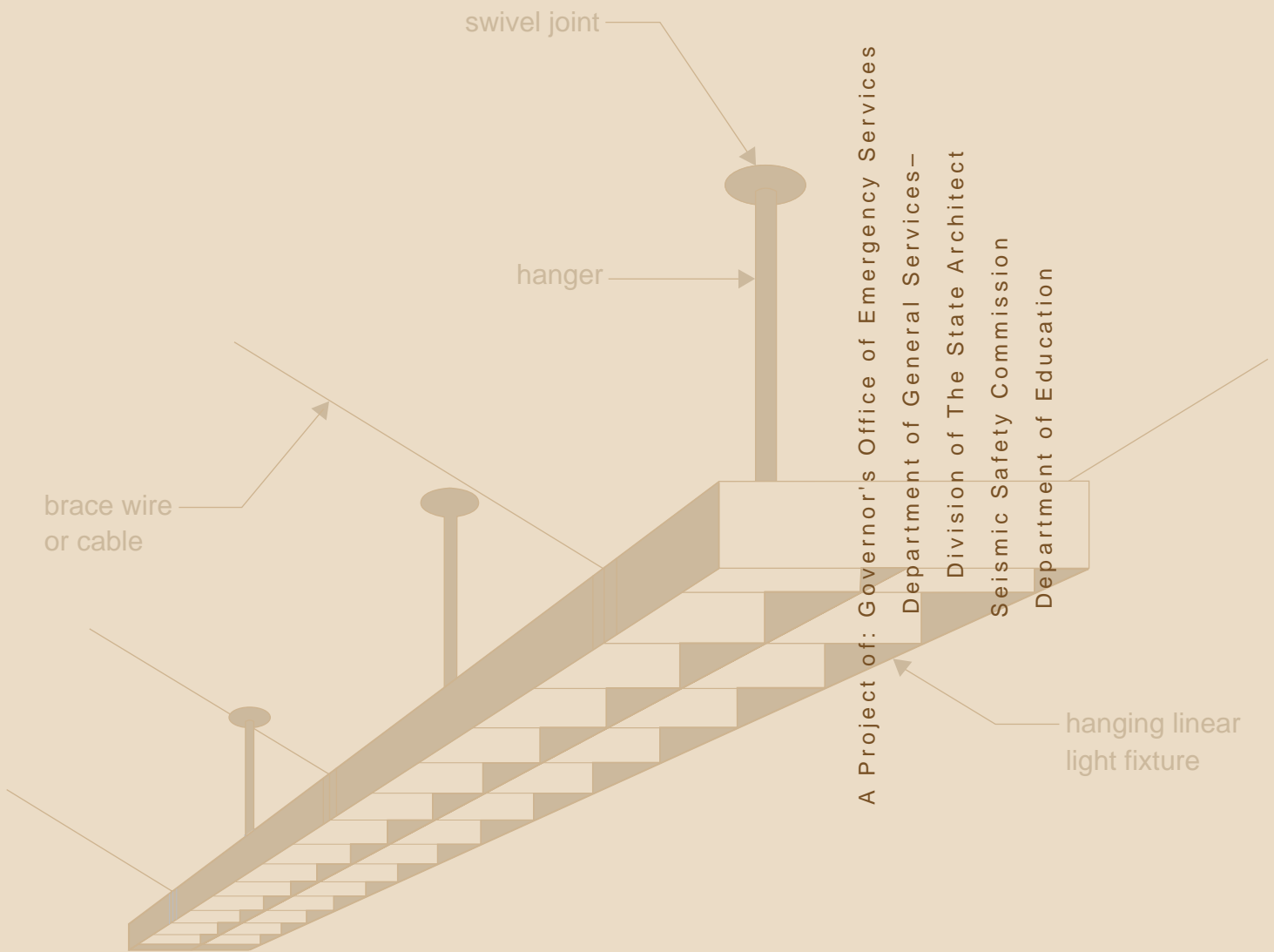

Safer Schools

GUIDE AND CHECKLIST FOR
**NONSTRUCTURAL
EARTHQUAKE HAZARDS**

IN CALIFORNIA SCHOOLS

Gray Davis
Governor

A Project of: Governor's Office of Emergency Services
Department of General Services—
Division of The State Architect
Seismic Safety Commission
Department of Education

Acknowledgements

The project is authorized in Government Code Section 8587.7 (SB 1122 Alarcon, Statutes of 1999).

Special acknowledgment should be give to *the Staff of the Department of General Services – Division of the State Architect* for developing the graphics and content of *the Guide and Checklist for Non-structural Earthquake Hazards in California Schools*.

The following persons participated in the development and review of this report:

Governor's Office of Emergency Services

Carrie Barnecut, Coastal Region Earthquake Program, Project Lead

Kathleen Bailey, Coastal Region Earthquake Program

Richard Eisner, FAIA, CISN and Earthquake Program

Rick Castro, Legislative Affairs

Lloyd Dillon, Planning and Technological Assistance Branch

Phyllis Cauley, Acting Regional Administrator, Coastal Region

Wendy Gibson, Planning and Technological Assistance Branch

Grace Koch, Executive Programs and State Operations

Jim Brown, Inland Region

Ann Tanouye, Southern Region

Department of General Services – Division of the State Architect

Dennis Bellet, Chief Structural Engineer

Howard Smith, District Structural Engineer

Terence Fong, District Structural Engineer

Annie Dang, Graphic Designer

Justin Nogarr, Graphic Designer

California Seismic Safety Commission

Fred Turner, Staff Structural Engineer

Department of Education



Disclaimer

The recommendations included in this document are intended to reduce seismic hazards associated with the non-structural components of school buildings, including, but not limited to mechanical systems, ceiling systems, partitions, light fixtures, furnishings, and other building contents. At this time, earthquake engineering is not an exact science and cannot accurately predict the performance of non-structural elements or guarantee adequate earthquake protection if the guidelines in this publication are followed.

This publication does not address risks associated with the failure of structural elements of school buildings, such as the collapse of walls, columns or roof systems. The recommendations contained herein do not guarantee the safety of any individual structure or facility during an earthquake and should be interpreted and used in a manner consistent with the overall unique safety requirements of each school facility.

Expertise of qualified California licensed design professionals is recommended to increase the probability that intended levels of earthquake protection will be achieved. Liability for any losses that may occur in an earthquake or as a result of using this publication is specifically disclaimed. The State of California specifically disclaims liability for any injury, death, or property damage that may occur during or after an earthquake, or as a result of the use of this publication.

The project is specifically authorized by Government Code Section 8587.7 (SB 1122 Alarcon, Statutes of 1999) as part of the overall emergency preparedness efforts authorized by the California Emergency Services Act.

Introduction

This publication identifies potential earthquake hazards associated with non-structural components of school buildings, and provides recommendations for mitigating those hazards. Non-structural components include furnishings and equipment, electrical and mechanical fixtures, and architectural features such as suspended ceilings, partitions, cabinets and shelves. In general, Non-structural components and building contents become hazards when they slide, break, fall, or tip over during an earthquake. Securing the Non-structural components and building contents improves safety and security of the school facility during an earthquake emergency by:

- Reducing the potential for fatalities and injuries.
- Helping to maintain safe and clear exit ways for evacuation and to access the building.
- Reducing the potential for chemical spills, fires and gas leaks.
- Improving the probability of using the school facility as a shelter following an earthquake.

“
Non-structural components and building contents were sources of injury [in the Coalinga earthquake]. Many of the injuries could have been avoided, either by modifying the physical setting or providing better public information on appropriate behavior both during earthquake shaking and following the event.

*Kathleen Tierney
Report on the Coalinga Earthquake
September 1985*

Based on what I saw during my visits to schools in the [epicentral] area, there would have been numerous injuries from nonstructural hazards if the Loma Prieta earthquake had occurred during school hours.

*Dennis Bellet
Chief Structural Engineer
Department of General Services –
Division of the State Architect*

We had done some preparation. We had attached all cabinets and shelves to the walls with angle brackets into studs so most of them withstood the quake [October 17, 1989] quite well...it was only the rooms where they had not been attached or they were in the center where they fell over. Cabinets or shelves taller than about three feet fell over.

*Kenneth Simpkins, Superintendent
Loma Prieta Joint Elementary School District
Los Gatos, CA*”

Using this publication

The non-structural components and building contents identified in this publication are listed in one of the following three sections:

- 1 Ceiling and Overhead** (Page 5 to 18)
- 2 Walls and Wall-mounted** (Page 19 to 28)
- 3 Furniture and Equipment** (Page 29 to 48)

Within each section, an information sheet is provided for each non-structural component or building content item. Each information sheet provides:

- Description of the item
- A description of the potentially hazardous condition
- Recommendations to reduce the hazard

In some cases, the information sheet will specify that a qualified California licensed architect or engineer must be consulted in order to properly assess and mitigate an identified hazard.

An **Earthquake Hazards Checklist** form is also provided at the back of this publication to assist district staff in conducting a non-structural hazards survey. One form can be completed for each room within a school building. It is recommended that all buildings on a school campus be surveyed.

The form may be photocopied, or additional forms may be downloaded and printed from the Division of the State Architect's web site at www.dsa.dgs.ca.gov, click on "publications", click on "Guide and Checklist for Non-Structural Earthquake Hazards in California's Schools."

Classroom safety may be improved significantly by completing a number of "quick action items" prior to completing a formal inventory. The following are suggested quick action items:

- Store heavy items on lower shelves (below the height of occupants). Do not place heavy items or full boxes on tall furniture.
- Secure hanging plants or hanging displays with closed hook hangers.
- Place tall file cabinets and shelving (over 4 feet) in low occupancy areas (such as a closet).
- Secure desktop equipment and displays that could fall and injure occupants.

Additional resource information is available on "Seismic Design Criteria of Non-Structural Systems for New School Facilities and Existing Facilities," the CD accompanying this guide, or on the internet by searching "seismic restraints." A resource/ references list is also provided on page 49 of this publication.

Any questions regarding the use of this publication may be directed to:

*Department of General Services –
Division of the State Architect
916.445.8100*

Light Fixtures - Hanging / Pendant

Single fixtures or linear light fixtures that are suspended below the ceiling must have a safety cable, and the fixture must be restrained against swinging unless there is adequate clearance to other objects. Light fixture luminaires, lenses or diffusers must be fastened securely to the fixture.

Recessed Light Fixtures at Suspended Ceiling

Fluorescent light fixtures installed in a suspended grid ceiling system must have wires connecting the fixture to the structure above. Luminaires, lenses or diffusers must be fastened securely to the fixture.

Recessed HVAC Registers at Suspended Ceiling

Heating, Ventilation, Air Conditioning (HVAC) registers installed in a suspended grid ceiling system must have wires connecting the fixture to the structure above. HVAC grills (air vents) must be securely fastened to the fixture.

Suspended Ceilings (metal grid with lay-in acoustical panels)

Suspended ceilings must have diagonal bracing wires within the attic space, connecting the metal grid to the structure above. One set of four brace wires should be spaced each 12 feet on center each way.

Hanging Displays & Plants

Hanging plants, mobiles, or displays must have closed eye-hooks at each end of the hanger, and must be able to swing freely at least 45° in any direction without striking other objects (i.e. wall, light fixtures).

Suspended Space Heaters / Air Conditioning (AC) Units

Space heaters suspended from a ceiling or roof must be braced to resist lateral movement, and should have flexible gas connections to the gas service piping.

Decorative Ceiling / Lattice Work

Decorative or sound-absorbing ceiling panel, and latticework must be securely attached to the ceiling framing, or if suspended below a supporting ceiling or roof, must be braced to the supporting structure.

Page

7

8

8

9

10

11

12



Conduits / Piping

Electrical conduit, gas, plumbing and fire sprinkler piping, and conduit/pipe trapezes are typically located above ceilings. Large conduits/pipes and trapezes, if suspended from the roof or floor structure above, must be braced to the roof or floor structure to resist horizontal movement.

Ductwork

HVAC ducts are typically located above ceilings. Large ducts, if suspended from the roof or floor structure above, must be braced to the roof or floor structure to resist horizontal movement.

Lath & Plaster Soffit (exterior)

Plaster soffits (typically at the underside of exterior overhangs and entries) that have any evidence of distress, substantial cracking, water intrusion, or separation from the structure should be inspected by a qualified architect or engineer.

Tile Roofing (exterior)

All roof tiles must be secured to the roof structure with two fasteners at each tile, or alternatively may utilize a wire tie system. Unsecured tiles can fall off the roof in an earthquake (check roof at entries/exits).

Unreinforced Masonry Chimney (exterior)

Older buildings (built prior to 1960) may utilize un-reinforced and inadequately secured masonry chimneys, projecting above the roof. These should be removed and replaced with an approved metal flue assembly.

Page

13

14

15

16

17



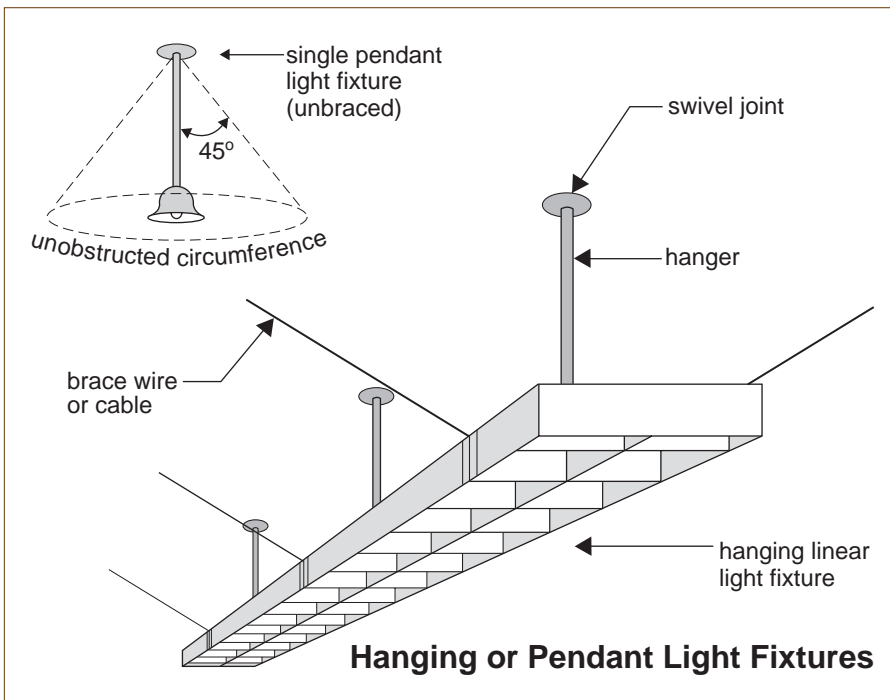

Hazards

Unsecured light fixtures:

- may fall, striking occupants below, or damaging electrical wiring that could start a fire or electrocute nearby occupants.
- may swing, damaging nearby light fixtures, ducts or pipes.

Recommendations

- Secure light fixtures to structural floor or beam above with bracing cables or wires. Provide transverse and longitudinal bracings.
- Secure single pendant fixture to structural floor or beam above with four way splay wires.
- As an alternative to bracing, provide clear space around light fixtures to allow them to swing without contacting obstruction in any direction.

Notes

- Light fixture must have swivel joint at top so that they can swing freely in all direction.
- Bracings and hangers for pendant light fixtures should be installed into structural floor slab, beams, or blocking above.

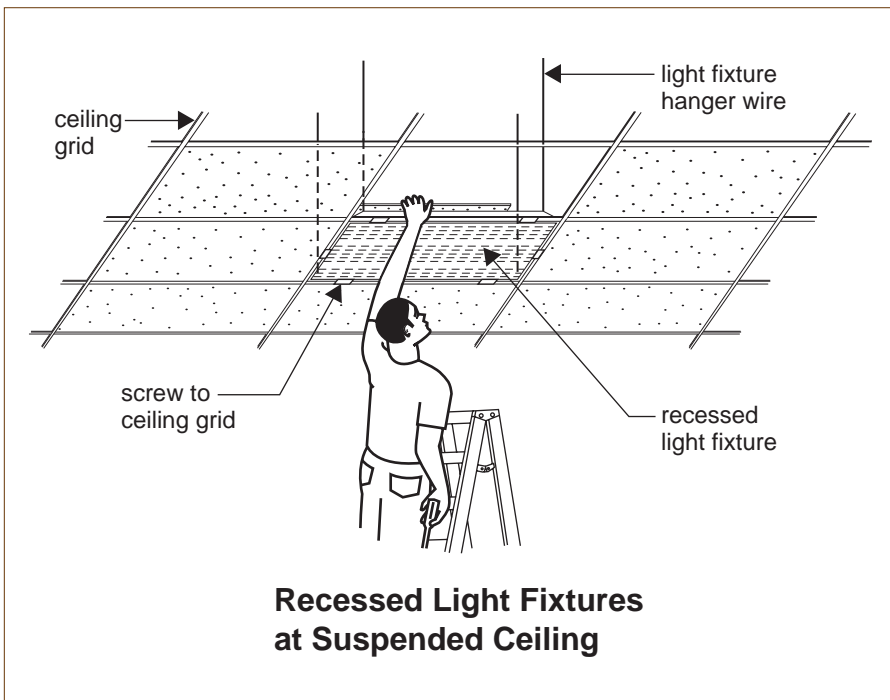

Hazards

- Unsecured ceiling mounted light fixtures and HVAC registers may fall, striking occupants below or blocking exit ways for evacuation during an emergency.

Recommendations

- Fasten light fixtures, and HVAC registers to the ceiling grid with sheet metal screws on all four sides.
- Install minimum of two hanger wires at diagonal corners of light fixtures or HVAC registers
- Attach hanger wires to beams or floors above.

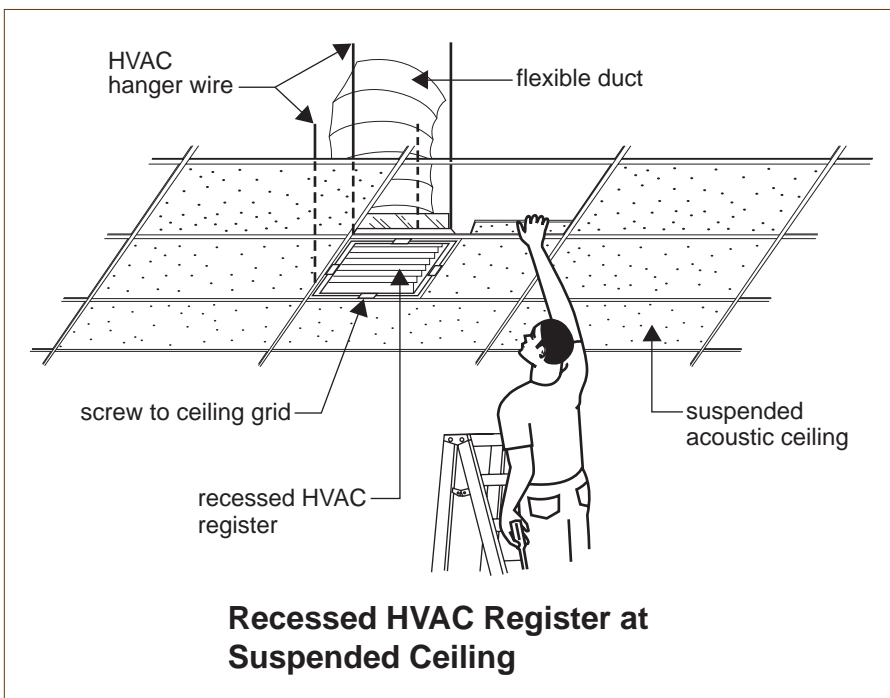

Notes

- If light fixtures or HVAC registers weighs 56 lbs. or more, use four hanger wires (one at each corner).
- Use flexible cables to wire light fixtures to existing/new electrical cables in the building
- Use flexible duct to hook up HVAC registers to existing/new ducts in the building.

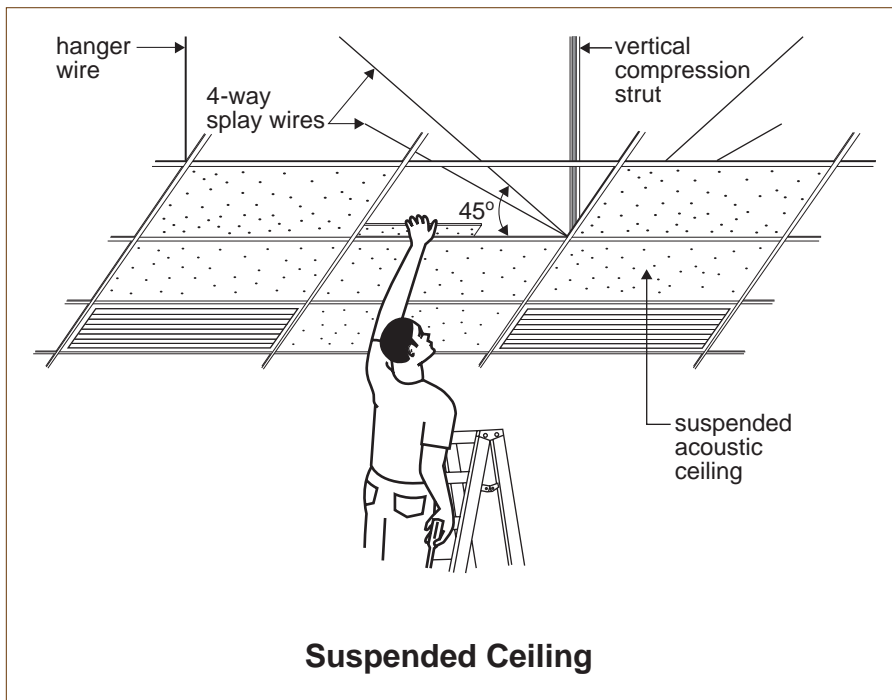

Hazards

- Unsecured suspended ceiling may fall, striking occupants below or blocking exit ways for evacuation during an emergency.

Recommendations

- Provide 4-way bracing wires and compression struts (see drawing).

Notes

- Provide a set of 4-way bracing wires for every 12 feet x 12 feet area.
- Provide a compression strut at each bracing wire location.
- Suspended acoustical ceiling must be intermediate or heavy duty rated.

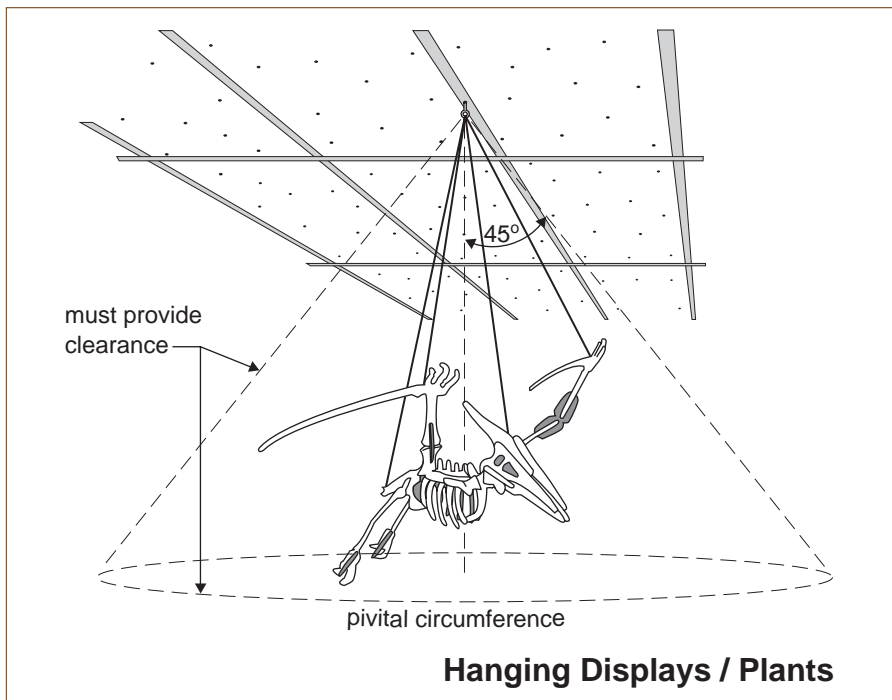

Hazards

Hanging display:

- may fall, striking occupants below or blocking exit ways for evacuation during an emergency.
- may sway, striking nearby objects and causing them to fall.

Recommendations

- Hang displays from beams or floor above. Do not hang from suspended ceilings.
- Provide adequate clearance around the display, so that it could sway without contacting obstructions.

Notes

- Relocate display away from doors or exits.

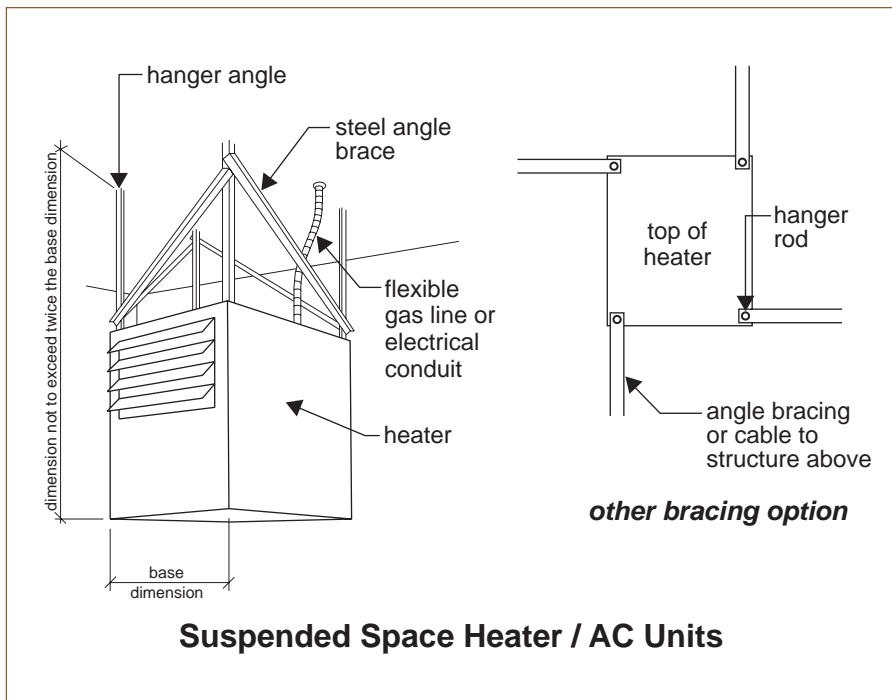

Hazards

Unsecured suspended space heaters/AC units

- may fall, striking occupants below, damaging electrical wires that may cause electrical shocks and fire, or blocking doors and exit ways during an emergency.
- may sway, damaging nearby pipes, ducts, ceilings, walls or conduits.

Recommendations

- Provide diagonal braces that are attached to the equipment at four corners (see drawing).
- Provide diagonal braces that are attached to hanger rods (see drawing).

Notes

- Space heaters/AC units must be suspended by hanger rods or steel angles.
- Space heaters/AC units must have flexible pipes or conduits connected to it.
- Relocate space heaters/AC units away from doors, and exit ways.
- Consult a qualified architect or engineer to determine the bracing requirements.

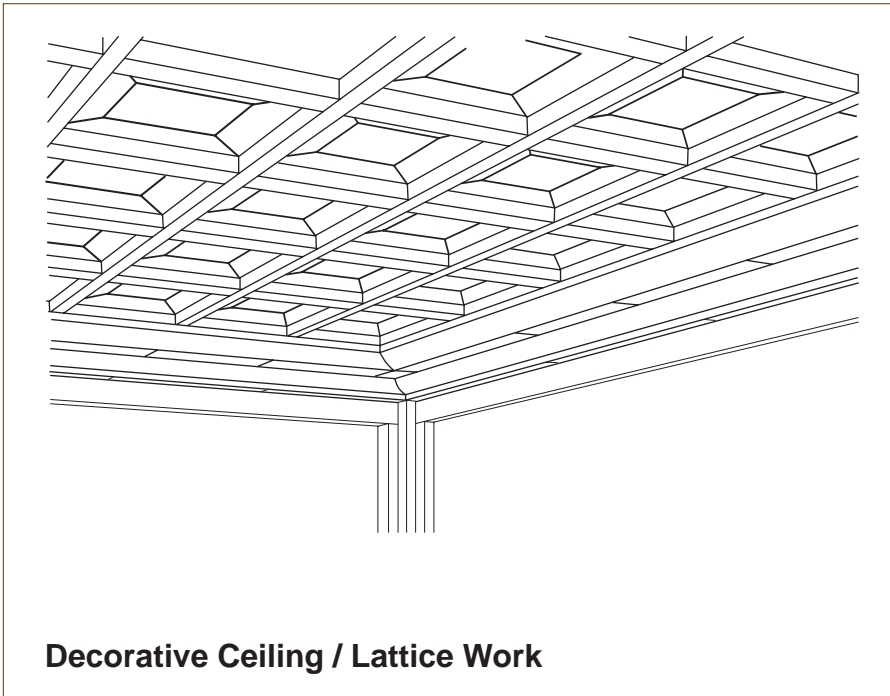
**Hazards**

- Unsecured decorative ceiling/ lattice work may fall, striking occupants below or blocking hallways and exit ways during an emergency.

Recommendations

- Brace decorative ceiling/ lattice work with splay wires similar to suspended ceilings (see page 9.)

Notes

- Decorative ceiling/ lattice should have compression struts for splay wires.

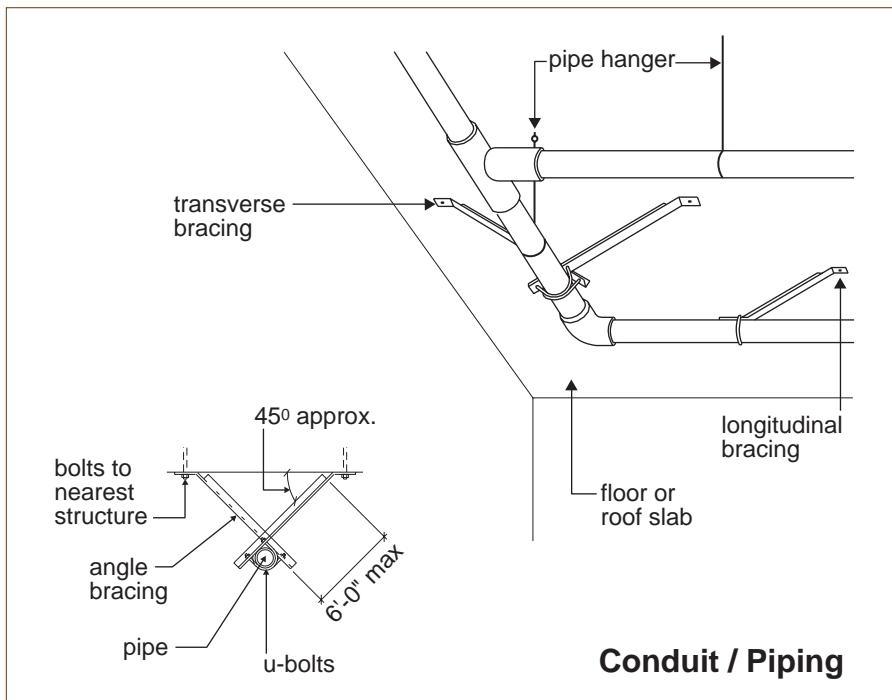

Hazards

- Pipe may fall and striking occupants below.
- Gas pipe may break and causing fire or explosion.
- Pressure pipe may break and becoming a live “whip” that could injure nearby occupants.
- Steam pipe may break, burning occupants below or nearby.

Recommendations

- Secure pipe with transverse and longitudinal bracing.

Notes

- Design of transverse bracing and longitudinal bracing should be determined by a qualified architect, structural engineer, or mechanical engineer.
- Use pipe fittings to attach bracing to pipe.
- Attach bracing to structural floor beams or blocking above. Do not attach bracing to suspended ceilings.
- Bracing not required for fuel piping less than 1 inch inside diameter.
- Bracing not required for piping less than 2.5 inch diameter except medical gas including vacuum piping.
- Bracing not required for piping suspended by individual hangers 12 inches or less in length.

Resources

- Sheet Metal and Air Conditioning Contractor National Association (SMACNA), Seismic Restraint Manual Guidelines for Mechanical Systems.

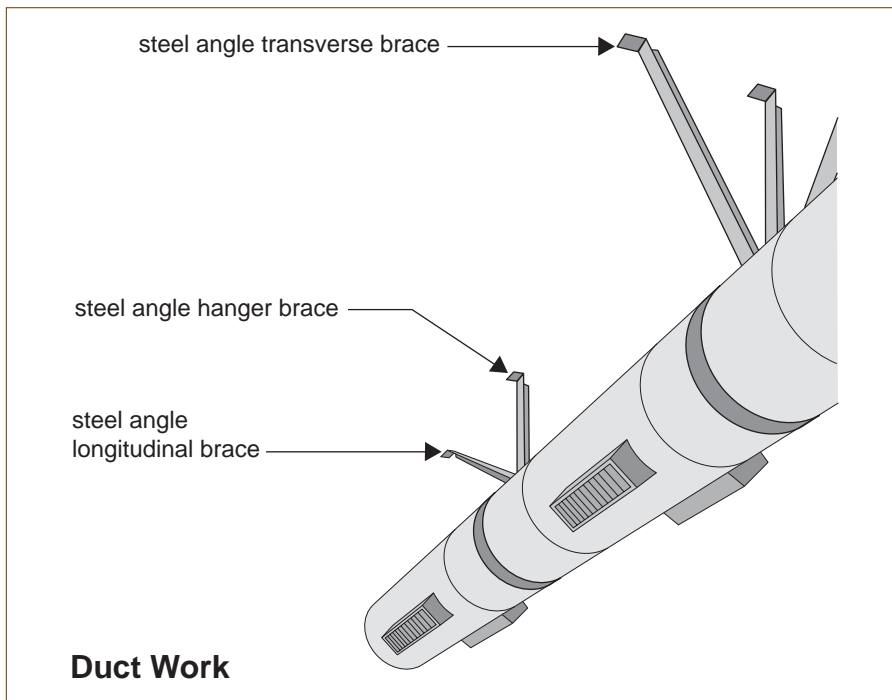

Hazards

- Unsecured ducts may fall, injuring occupants below.
- Fallen ducts may block exit ways.

Recommendations

- Secure ducts with transverse and longitudinal braces.
- Attach braces to ducts with proper duct fittings.
- Attach braces to structural floors or beams above with concrete drill-in anchor bolts or lag bolts.

Notes

- Design of transverse and longitudinal bracing should be determined by a qualified architect, structural engineer, or mechanical engineer.
- Use concrete drill-in anchor bolts for concrete construction.
- Use lag bolts for wood construction. Lag bolts should be installed in beams or blocking.
- Bracing not required for rectangular ducts when the width (W) and height (H) dimensions in feet are such that $W \times H$ is less than 6.
- Bracing not required for round ducts with diameter less than 28 inches.

Resources

- Sheet Metal and Air Conditioning Contractor National Association (SMACNA), Seismic Restraint Manual Guidelines for Mechanical Systems.

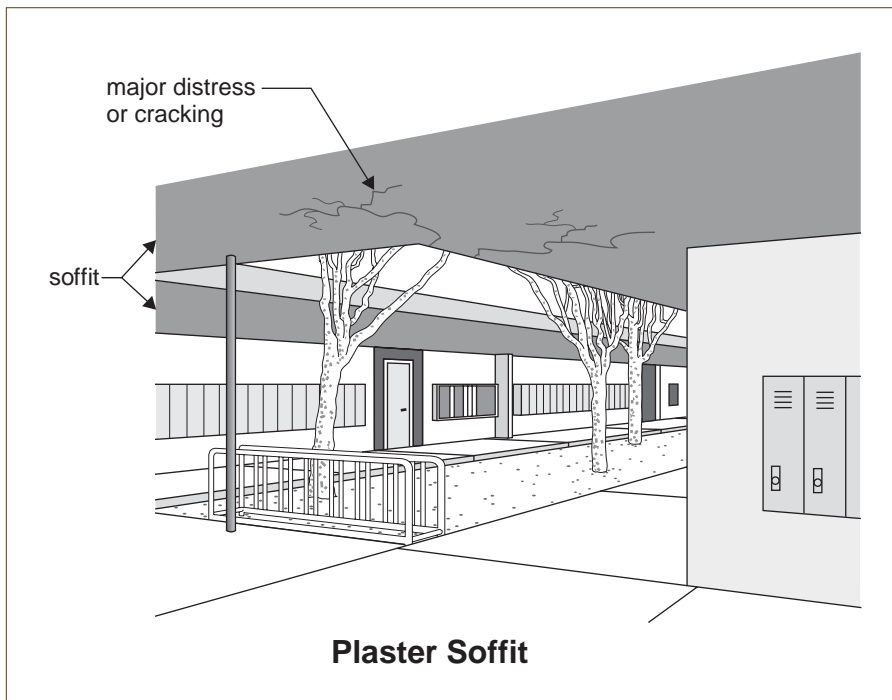
**Hazards**

- Deteriorated plaster may collapse, striking occupants below or blocking hallways and exit ways during an emergency.

Recommendations

- Have the plaster soffit inspected by a qualified inspector, architect or structural engineer.
- Consult a qualified architect or structural engineer for repair as required.

Notes

- Inspect plaster ceiling or soffit if there are large cracks, excessive sagging, or separation from the substrate.

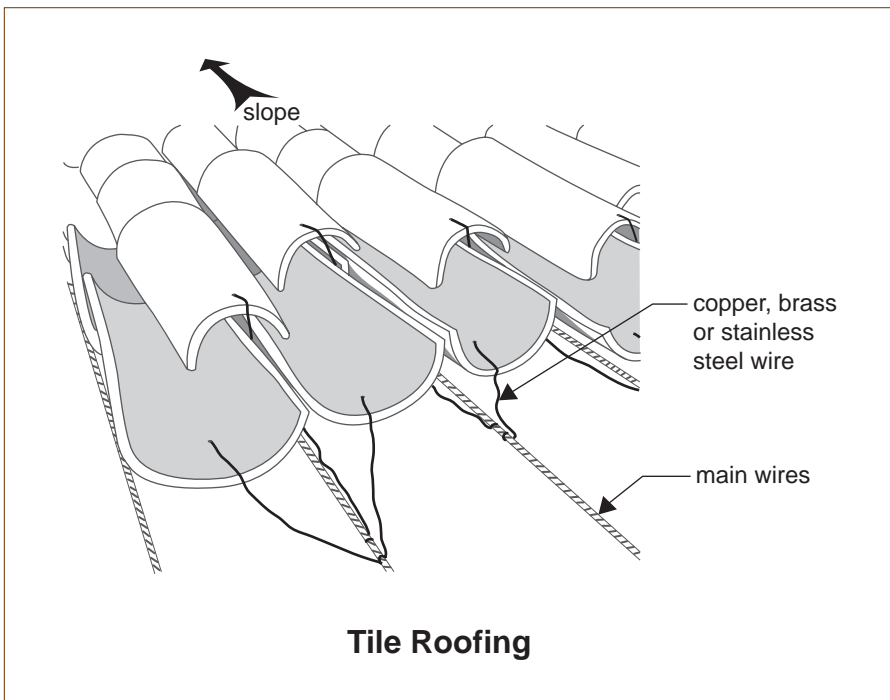

Hazards

- Unsecured roof tile may fall, injuring occupants below or blocking hallways and exit ways during an emergency.

Recommendations

Secure roof tiles with:

- copper, brass or stainless steel wires or,
- copper, brass or stainless steel nails.

Notes

- Wires must be capable of supporting four times the weight of tiles per California Building Code.
- Consult a qualified architect or structural engineer for seismic bracing requirements.

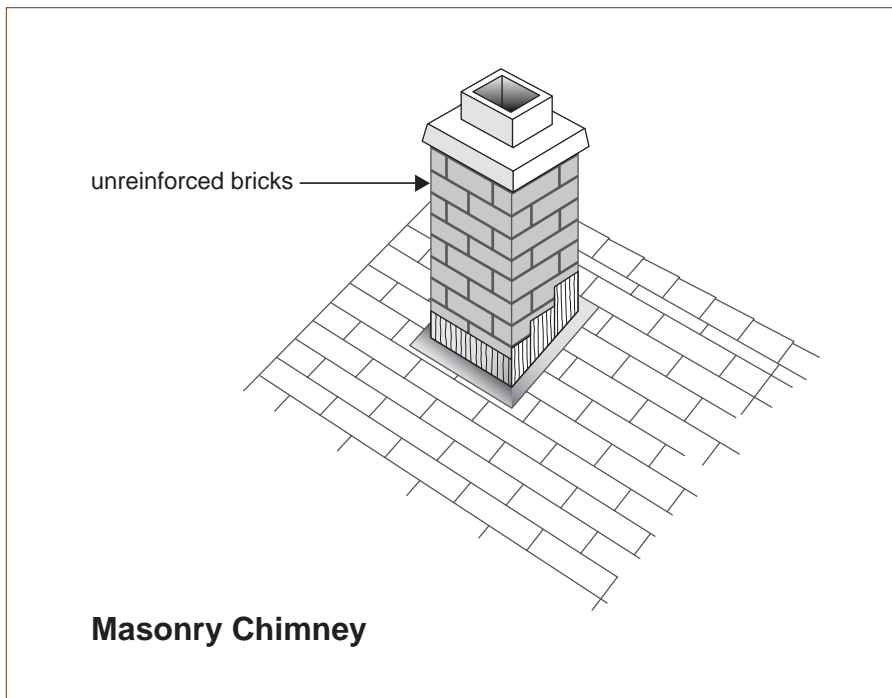

Hazards

- Unreinforced masonry chimney may collapse, striking occupants below or damaging roof and other structural elements supporting the building.

Recommendations

- Remove unreinforced masonry chimneys and replaced with an approved chimney with metal flue.

Notes

- Buildings built before 1960 may have unreinforced masonry chimneys.
- Consult a qualified architect or structural engineer for seismic requirements.

This page intentionally left blank.

Shelving

- Shelving frame must be securely fastened to wall framing.
- Shelves must be securely fastened to the frame.
- Shelves must have shelf lip or other means to restrain stored items.
- Chemicals or other hazardous materials stored on shelves must be segregated and secured.
- Heavier items should always be stored at lower level shelving.

Wall-Mounted Cabinets / Lockers / Coat Closets

Wall-mounted cabinets, lockers or closets must be securely fastened to wall study. Interior walls on which cabinets are mounted, if located in a room with suspended ceilings, should be checked as noted under “Walls and Partitions” below.

- Cabinet doors should have positive latching device or other means to secure in closed position.
- Shelving within wall-mounted cabinets should be checked per “Shelving” notes above.

Wall-Mounted TV, Video Monitors and Speakers

Wall-mounted TV or video monitors typically utilize a manufactured mounting bracket. The mounting bracket must be fastened to wall study. TV or video monitors must be secured to the bracket.

Pictures / Wall Decorations / Signs

Pictures or other wall-hung items should utilize closed eye-hook connectors and, except for light objects (< 5 pounds), the supporting hardware must be connected to wall framing (not only to drywall).

Fire Extinguisher

Wall-mounting hardware for fire extinguishers must be secured to wall studs. The fire extinguisher must be secured to the cabinet or bracket.

Interior Walls

Interior walls in rooms with a suspended ceiling (metal grid with lay-in acoustical panels) often terminate just above the ceiling level, and must be braced to the structure above, typically using diagonal stud members (wood or metal) or wires.

Page

21

22

23

24

25

26



Page

27

Free-Standing and Cubicle Partitions

Free-standing and cubicle partitions must be adequately braced to prevent horizontal movement at the top of the partition. Bracing is typically provided by connections to intersecting partitions or modular furniture. Particular attention should be given to partitions that support shelving or cabinets.

28

Entry Glass

Glass adjacent to or within an entrance or exit doors must be safety glass (i.e. tempered or laminated). Safety glass can be identified by an etched mark on each pane. Replacement of non-compliant glass with safety glass in these locations is recommended.

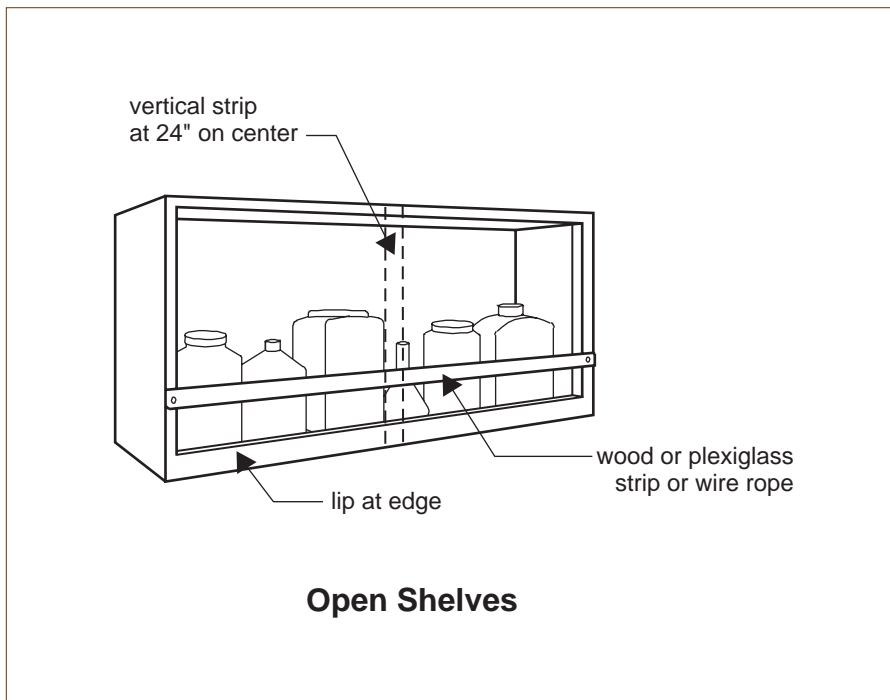

**Hazards**

Unsecured contents may fall off shelves,

- striking nearby occupants.
- spilling dangerous chemicals.

Recommendations

- Install wood or Plexiglas strips across open face of shelves (see drawing)
- Install doors on open shelves.
- Shelves must be secured.
- Install shelf with a lip to prevent objects from falling off the shelf.

Notes

- Relocate heavy items or volatile chemicals to floor mounted cabinets.

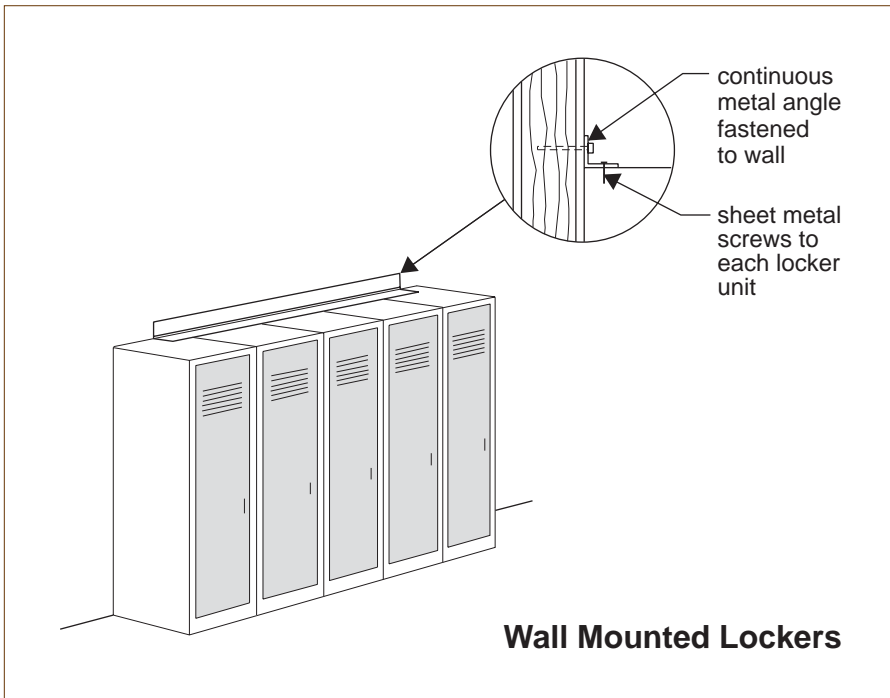

Hazards

- Unsecured wall mounted cabinets/lockers (shown)/ coat closets may fall, striking nearby occupants or blocking hallways and exit ways.

Recommendations

- For single unit, secure each unit to wall studs or blocking with screws.
- For multiple units, fasten each unit to a clip angle with sheet metal screws. Fasten clip angle to wall studs or blocking with screws .

Notes

- Relocate cabinets, lockers, or coat closets away from hallways and exit ways.

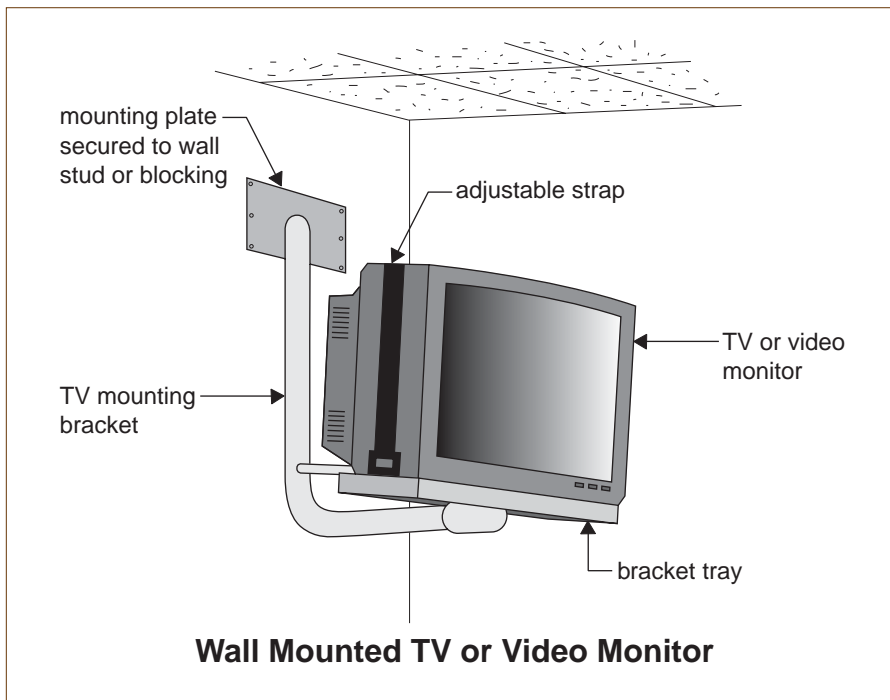

Hazards

- Unsecured TV, monitors, or speakers may fall off the mounting brackets, striking occupants below or blocking exit ways for evacuation during an emergency.
- A fallen T.V. or monitor may damage electrical wirings, exposing nearby occupants to electrical shock, causing interruption to electricity or starting a fire.

Recommendations

- Secure each TV or monitor to mounting bracket with adjustable strap, wrapping around the TV or monitor. Adjust strap for tight fit.
- Follow the recommendation provided by the manufacturer for mounting bracket for TV, video monitors, or speakers.
- Locate TV/monitor mounting brackets away from doors or exit ways.

Notes

- Mounting bracket must be installed per manufacturer's instructions.
- TV, video monitors, or speakers must not exceed the manufacturer's recommended weight limit.
- Consider using a pre-approved mounting bracket and installation from the Office of Statewide Health Planning and Development (OSHPD).
- Consult a qualified architect or structural engineer for seismic bracing requirements.

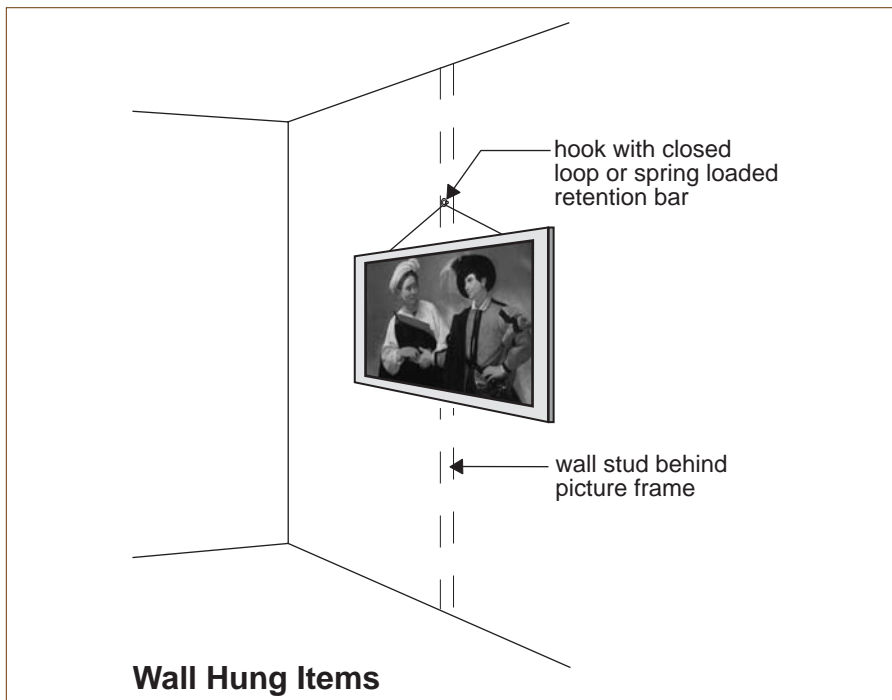

Hazards

- Unsecured wall hung items such as pictures, decorations or signs may fall, striking nearby occupants or blocking exit ways for evacuation during an emergency.

Recommendations

- Install hook into wall stud. Close hook with pliers after hanging item.
- Alternatively, use hook with spring-back retention bar.

Notes

- Do not hang an item that weighs more than recommended by the hook manufacturer.

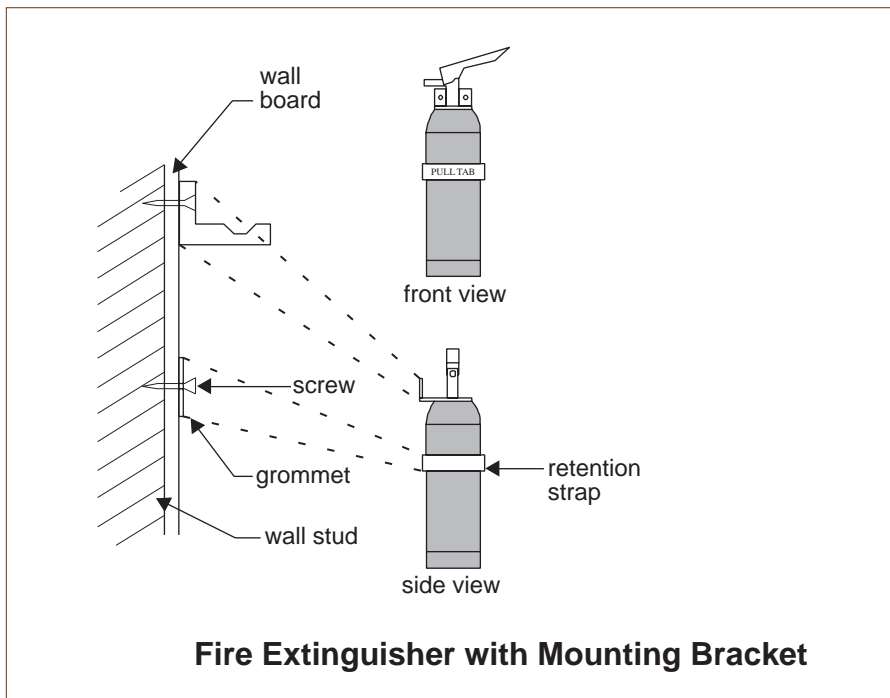

Hazards

- Unsecured fire extinguisher may fall off wall and damage the shut-off valve or hose, releasing its contents.
- A damaged fire extinguisher may not be functional in an emergency.
- Unsecured fire extinguishers may fall, striking nearby occupants.

Recommendations

- Secure fire extinguisher mounting bracket or cabinet to wall framing.

Notes

- The cabinet must be accessible either through breakable glass or latched door.

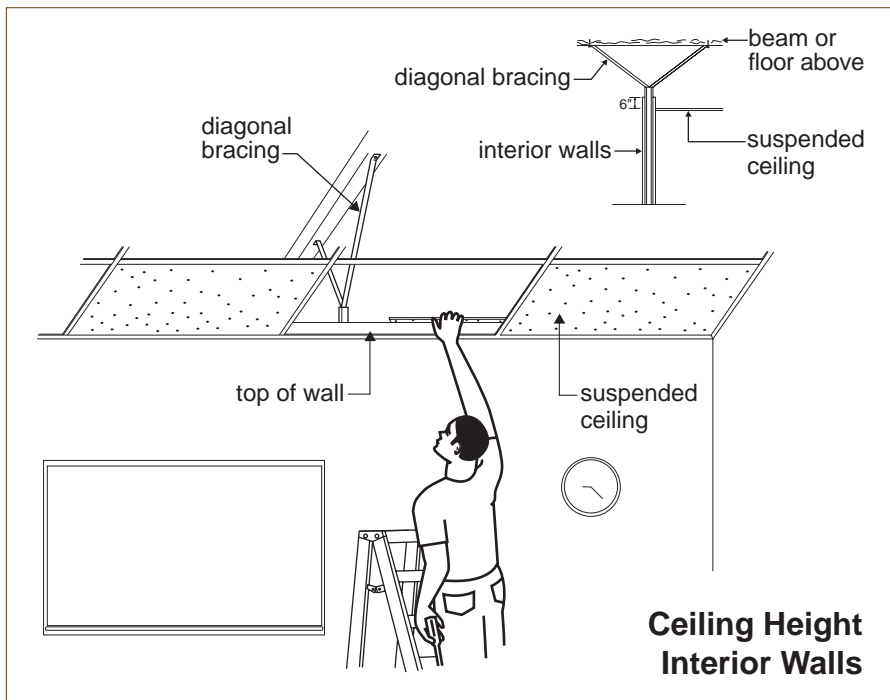

Hazards

Unsecured ceiling-height wall may fall,

- striking nearby occupants,
- blocking exit ways during an emergency,
- damaging pipes and electrical wiring in wall that may cause flooding, gas leaks, electrical shocks, fire, and interruption of utility services.

Recommendations

- Secure ceiling-height walls with diagonal bracing.

Notes

- Ceiling-height interior walls typically are walls erected to a height about 6" above ceilings.
- These walls usually are not fire-rated.
- Consult a qualified architect or structural engineer before hanging any cabinets or heavy objects on interior walls.
- Consult a qualified architect or structural engineer for seismic requirements.

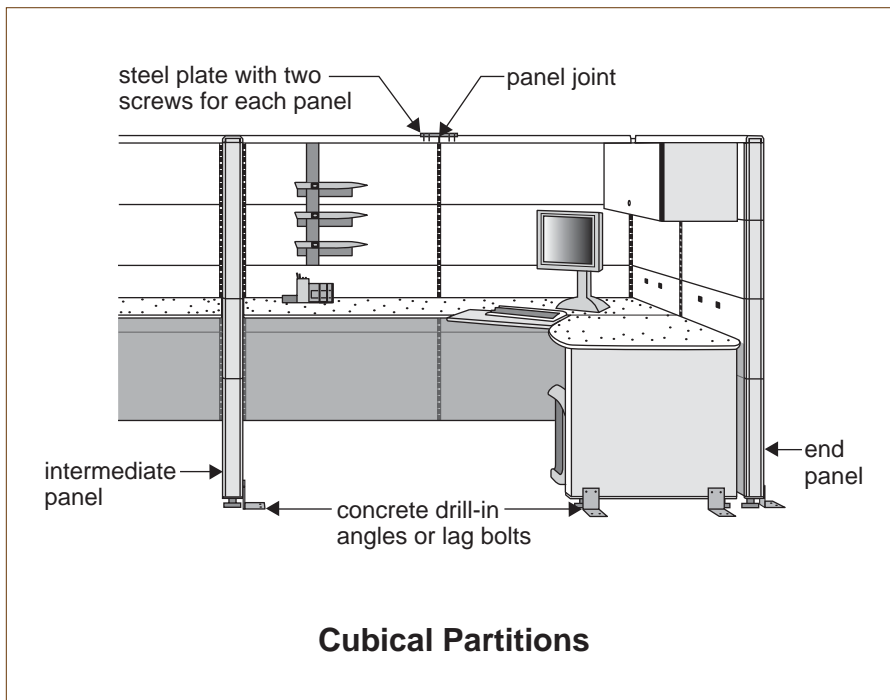
**Hazards**

- Unsecured cubical partitions may fall, injuring nearby occupants.
- Fallen cubical partitions may block doors and exit ways.

Recommendations

- Screw clip angle to intermediate and end panels at each end.
- Secure clip angle to concrete floor with concrete drill-in anchor bolt, or to wood floor with lag bolt at each leg. Lag bolt must be installed into floor joists or blockings.

Notes

- Clip angle must be screwed into the metal frame portion of the cubical partition. Do not attach to metal or plastic flashings.
- Maximum distance between intermediate or end panels is 10 feet.
- Panel joint must be rigid.
- If panels were hinged together or joints were not rigid, reinforce the top with steel flat plate across the joint and secure the bottom with clip angle (see drawing).
- Relocate heavy storage from upper shelves or bins.

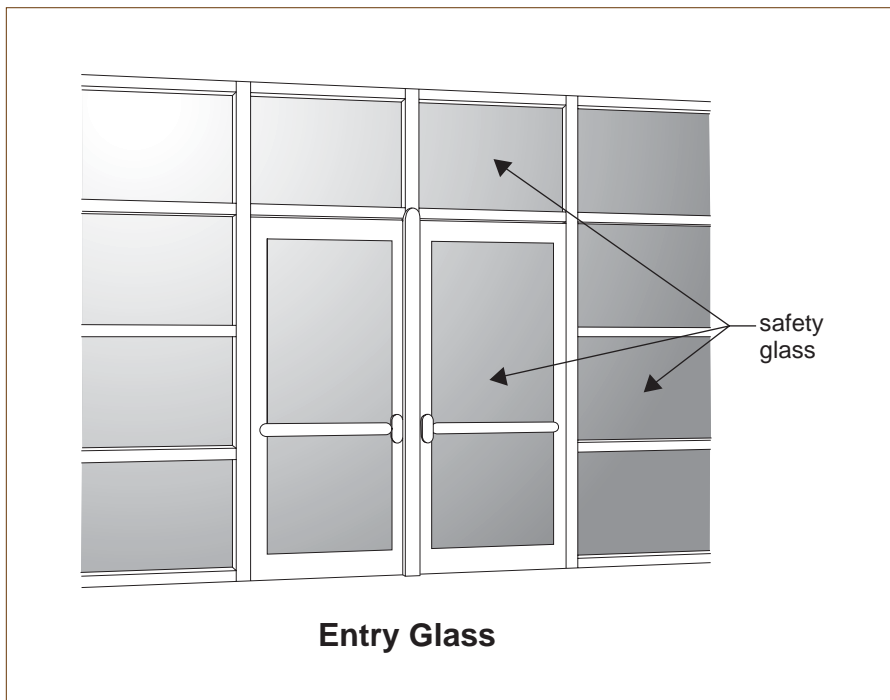
**Hazards**

Glass may fall,

- injuring nearby occupants,
- blocking doors and exits during an emergency.

Recommendations

- Replace glass on door and glass surrounding the door with safety glazing.

Notes

- Safety glass has permanent identification label etched or ceramic fired on the glass and readable from the inside of the building.
- Another name for glass is glazing.

File Cabinets

File cabinets more than 3 feet in height should either be arranged in groups and fastened together, or secured to an adjacent wall in order to prevent overturning. Cabinets must have latching drawers.

Bookcases

Bookcases more than 3 feet in height either should be placed back-to-back and fastened together, or should be secured to a wall. Library bookcases (+6 feet height) require floor or wall anchorage.

Desktop / Countertop Equipment

Desktop or countertop equipment should be secured to the desk, counter, or wall to prevent the equipment from sliding and falling from the desk or counter.

Equipment on Cart (video, projector)

When not in use, carts should have wheels locked, or alternatively, the cart can be tethered to an adjacent wall. Equipment should be secured to the cart.

Display Cases / Art Objects / Potted Plants

Free-standing objects may require restraint to prevent overturning. Heavy or sharp objects placed 3 feet or more above the floor should be restrained. Secure contents within display cases to prevent broken glass.

Aquariums

Free-standing aquariums must be secured to the floor and/or adjacent wall to prevent overturning. Aquariums which rest on a table, counter or shelf must be secured to prevent sliding.

Equipment on Wheels / Rollers (e.g. piano, chalkboard)

Free-standing equipment on wheels/rollers should have the wheels/rollers locked to prevent movement, or alternatively, the equipment can be tethered to an adjacent wall.

Office Equipment

Large or heavy office equipment should be restrained to prevent sliding, or located so that it will not block an exitway.

Page

31

32 / 33

34

35

36

37

38

39



Refrigerators / Vending Machines

Refrigerators, vending machines and similar equipment should be secured to the floor and/or adjacent wall, unless confined by cabinets, casework, or walls on three sides.

Shop / Gym Equipment

Free-standing shop or gym equipment should be secured to the floor (and/or wall) to prevent sliding and/or overturning. Weights and heavy tools should be properly stored (secured) when not in use.

Gas Cylinders

Compressed gas cylinders must be restrained (tethered to a wall or secured within a cabinet) to prevent overturning.

Gas Piping (shut-off valve & flexible connectors)

Shut-off valves must be provided at the gas service to any laboratory, mechanical or plumbing equipment, and an approved flexible connector should be provided between the shut-off .

Storage Racks

Storage racks must have cross-bracing and must be secured to the floor.

Electrical Equipment (cabinets, switchgear, transformers)

Electrical equipment must be restrained, and are typically anchored at the equipment base to the floor or concrete pad.

Mechanical Equipment (chillers, fans)

Mechanical equipment must be restrained, and are typically anchored at the equipment base to the floor or concrete pad.

Plumbing Equipment (water heater, tanks, pumps)

Plumbing equipment must be restrained, and are typically anchored at the equipment base to the floor, or are braced to an adjacent wall.

Kitchen Equipment (oven, range, hood, refrigerator/freezer, dishwasher)

Kitchen equipment must be restrained, and are typically anchored at the equipment base (legs) to the floor, or are braced to an adjacent wall.

Page

40

41

42

43

44

45

46

47

48



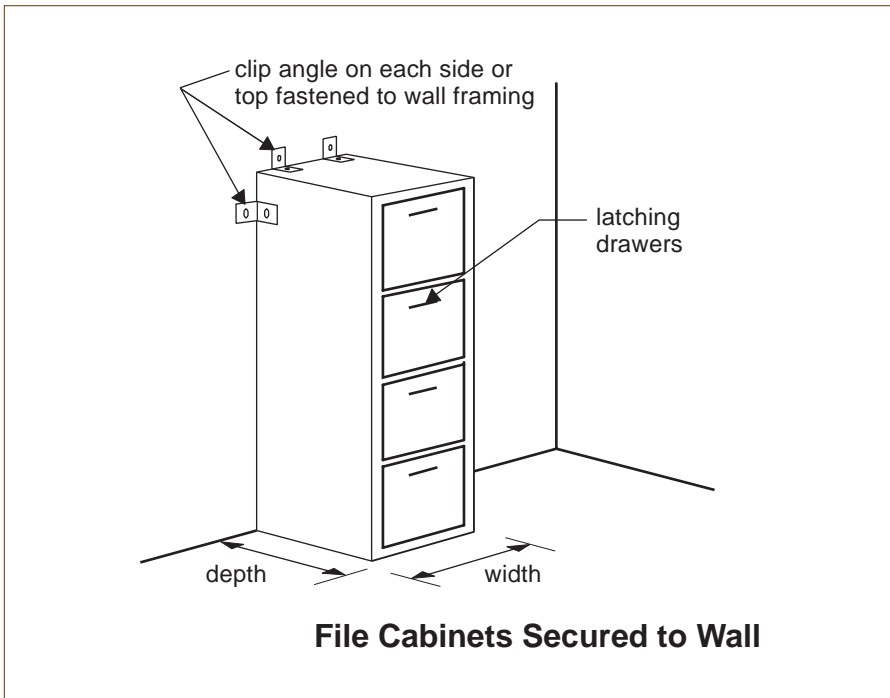

Hazards

- Unsecured cabinets may fall over during an earthquake.
- Unlatched drawers may open during an earthquake, which may cause the cabinet to fall over.

Recommendations

- When the cabinet depth or width (see illustration) is less than two-thirds the height, the cabinet should be secured to an adjacent wall, or fastened to adjacent cabinets.
- Cabinets should have latching drawers.
- Heavier contents should always be stored in lower drawers of a file cabinet.
- Locate cabinets away from exits and hallways.
- Keep cabinet drawers closed, latched, or locked.

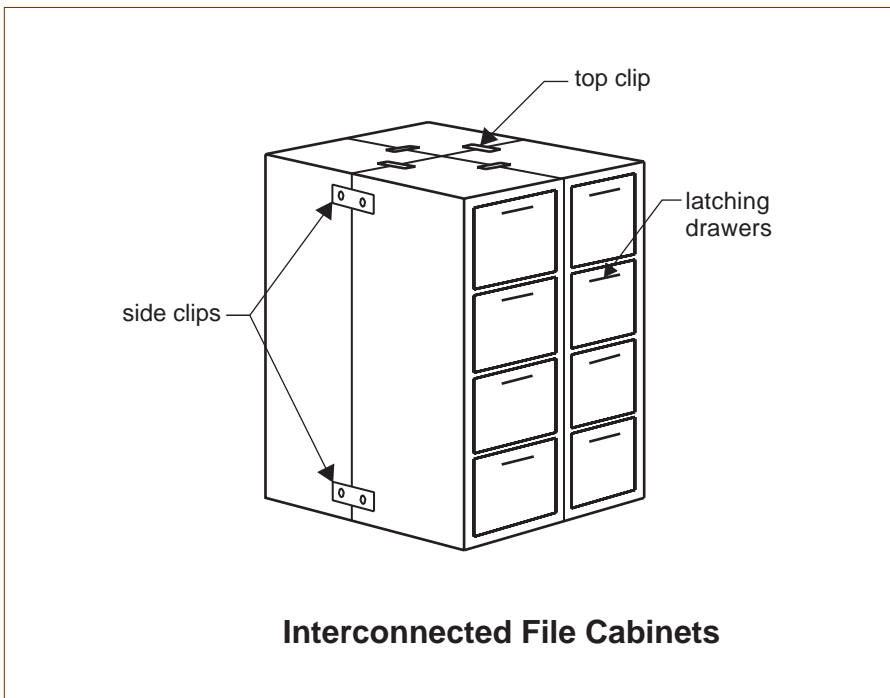

Notes

- Metal clips should be provided for attachments at cabinets and at walls.
- Metal clip attachments at the cabinet should utilize screws or bolts.
- Metal clip attachments at the wall should utilize screws that are properly installed into wall studs or blocking. Do not use toggle bolts (fastened to drywall).

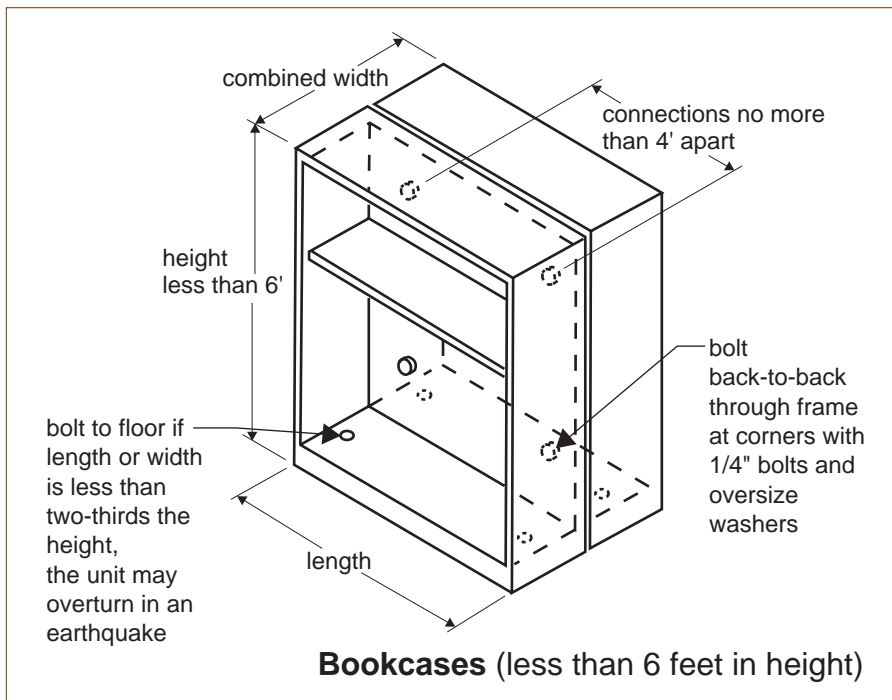

Hazards

- Unsecured bookcases may fall, striking nearby occupants or blocking doors and exit ways for evacuation during an emergency.

Recommendations

- Tie back-to-back bookcases together with clips and bolts or screws.
- Fasten bookcases to floor if the length or combined width is less than two-thirds the height to prevent tipping over.
- Fasten isolated bookcases to floor or wall.

Notes

- See Page 33 for bookcases greater than 6 feet in height.
- Relocate heavy books to lower levels.

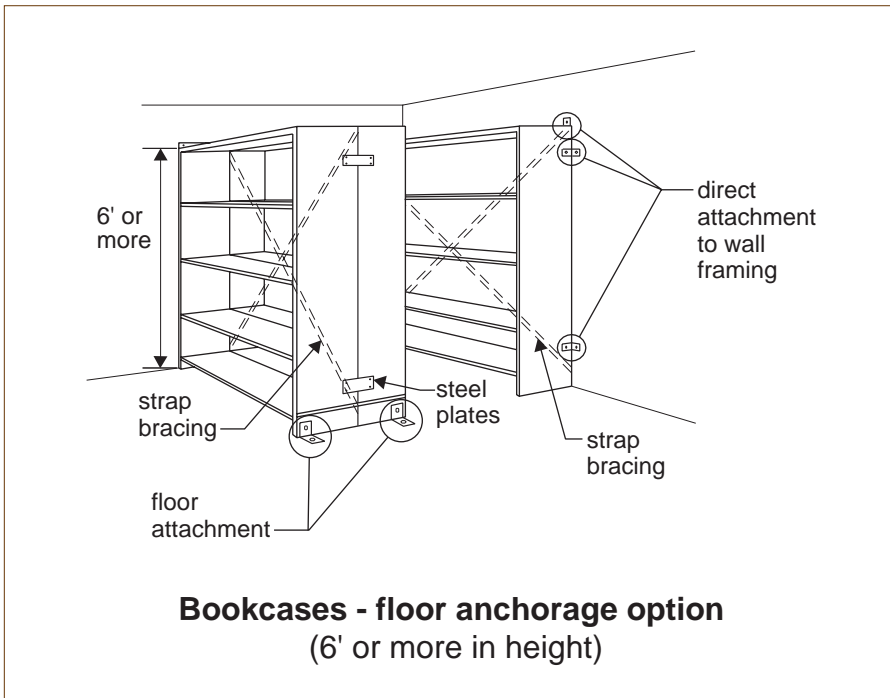

Hazards

- Unsecured bookshelves may fall and striking nearby occupants or blocking exit ways or doors during an emergency.

Recommendations

- Install cross bracing in back of bookcases. Use cable or metal strap for bracing.
- If bookcases were located back-to-back, tie them together with steel plates.
- Secure bookcases to wall or floor using clip angles.
- Alternatively, secure bookcases with anti-tip struts at top.
- For bookcases standing next to a wall, secure them to wall framing with clip angles.

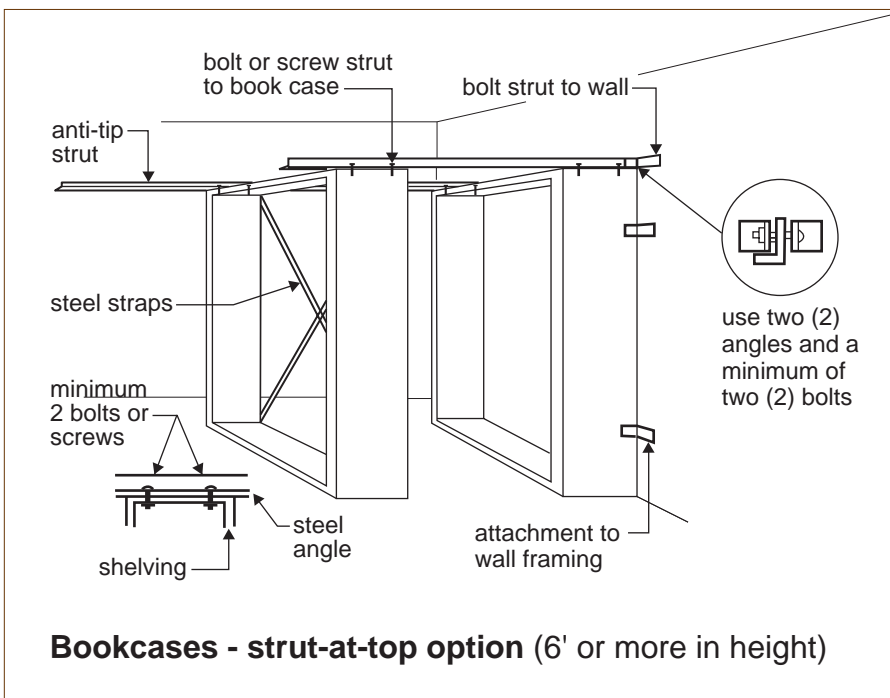

Notes

- Bolt or screw through framing of bookcases.
- Relocate heavy books to lower levels.

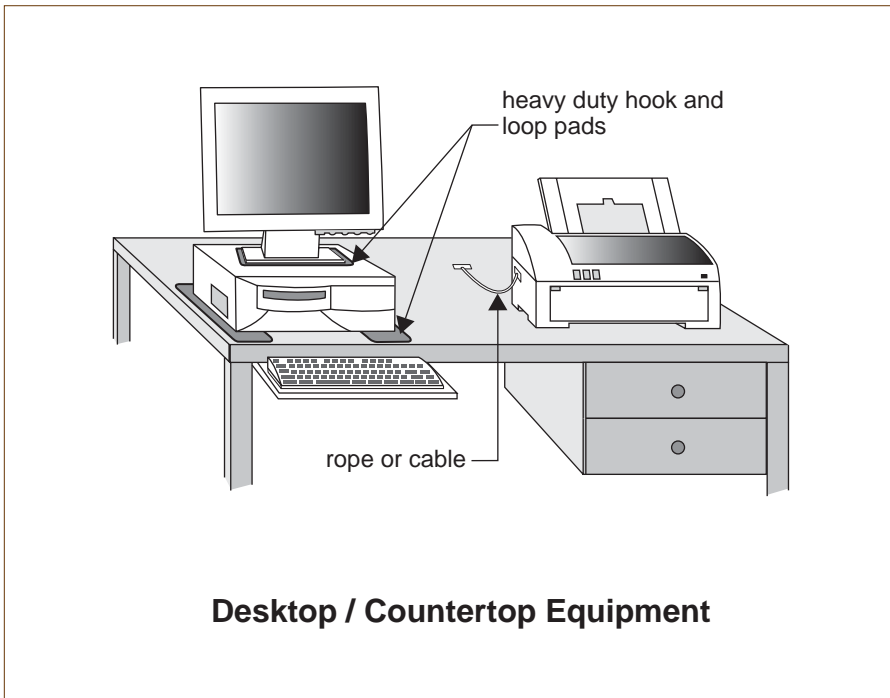

Hazards

- Unsecured desktop equipment may fall off desk, striking nearby occupants or blocking doors and exit ways.
- Fallen desktop equipment may damage electric wiring, causing power interruption, electrical shock to nearby occupants, or fire.

Recommendations

- Secure with heavy-duty hook-and-loop fasteners. Attach self-adhering hook-and-loop pads to base of desktop equipment case and the mating pads to desktop.
- Secure with cable or rope with self-adhering anchor pads to equipment and desktop.
- Relocate desktop away from doors and exit ways.

Notes

- For heavy countertop equipment such as an ice maker, consult a qualified structural engineer or architect.
- Many vendors supply various types of seismic fastening systems that may be used in lieu of the hook-and-loop system.

Resources

- Search the internet for “seismic restraints.”

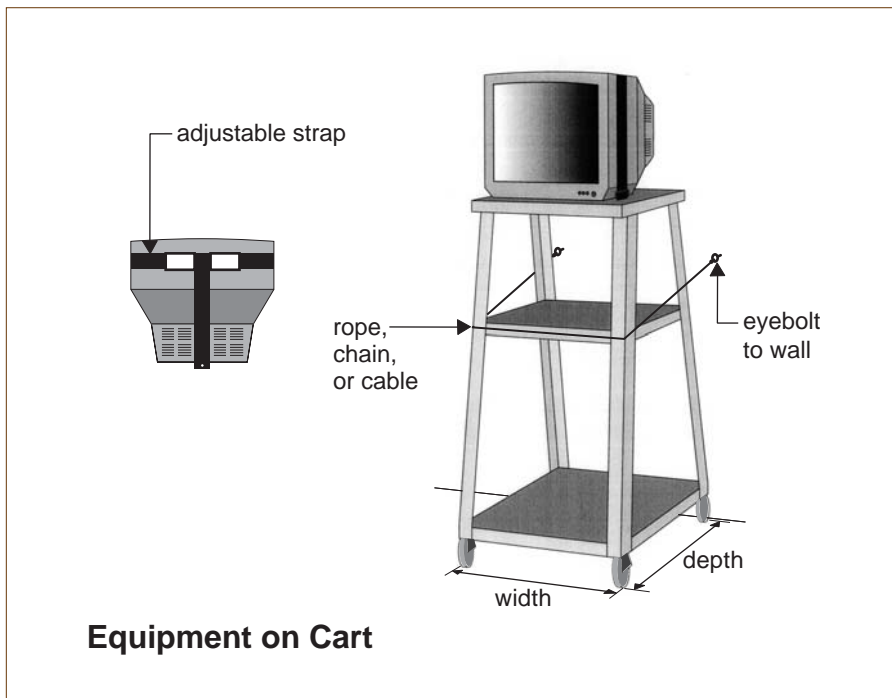
**Hazards**

- Equipment may fall off cart or topple cart, striking nearby occupants or blocking doors and exit ways.

Recommendations

- Secure equipment to cart with adjustable straps. Tighten strap to remove any slack.
- Relocate carts away from hallways and doors.

Notes

- Cart should have locking wheels or casters.
- If the height of the cart exceeds two thirds the depth or width of the cart (see drawing) , secure the cart to wall with rope, chain, or cable.
- Rope, chain, or cable should be attached to eyebolts or other closed loop fasteners, which should be installed into wall studs or blocking.

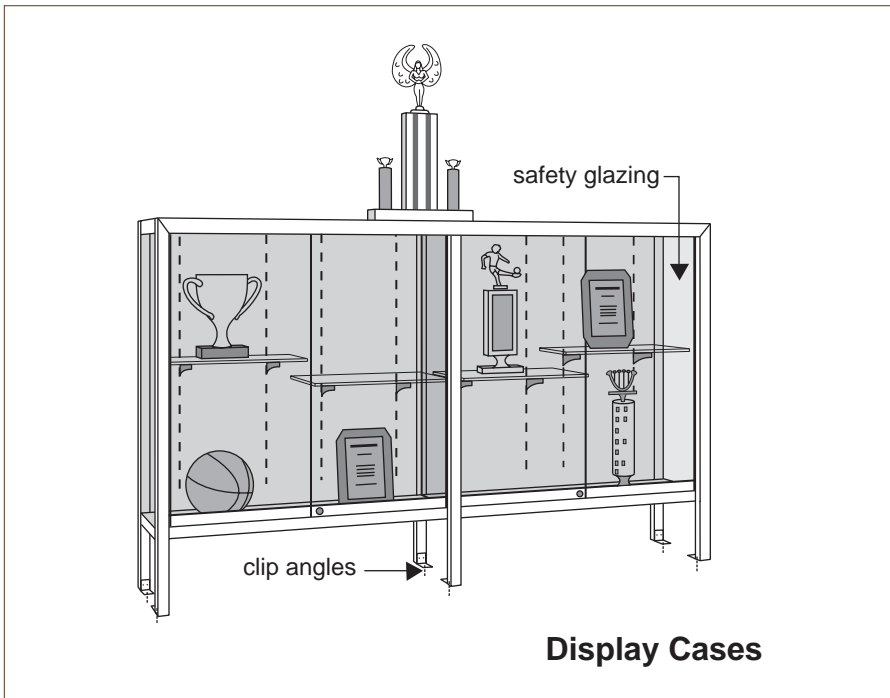

Hazards

- Unsecured display and potted plant may fall, striking nearby occupants or blocking doors and exit ways for evacuation during an emergency.

Recommendations

- Secure display case to floor.
- Use angle bracket if needed.
- Secure contents to shelves using hook-and-loop or similar devices.
- Secure art objects or potted plants with ropes, chains or cables attached to eyebolts installed into wall studs or blocking.

Notes

- Display case must have safety glass.
- Shelves in display case must be secured.

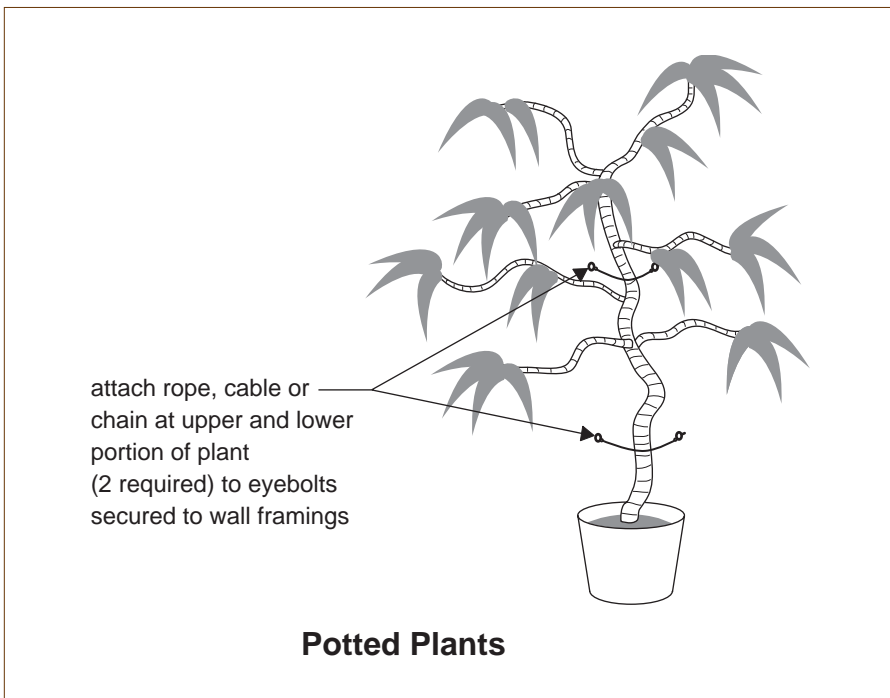

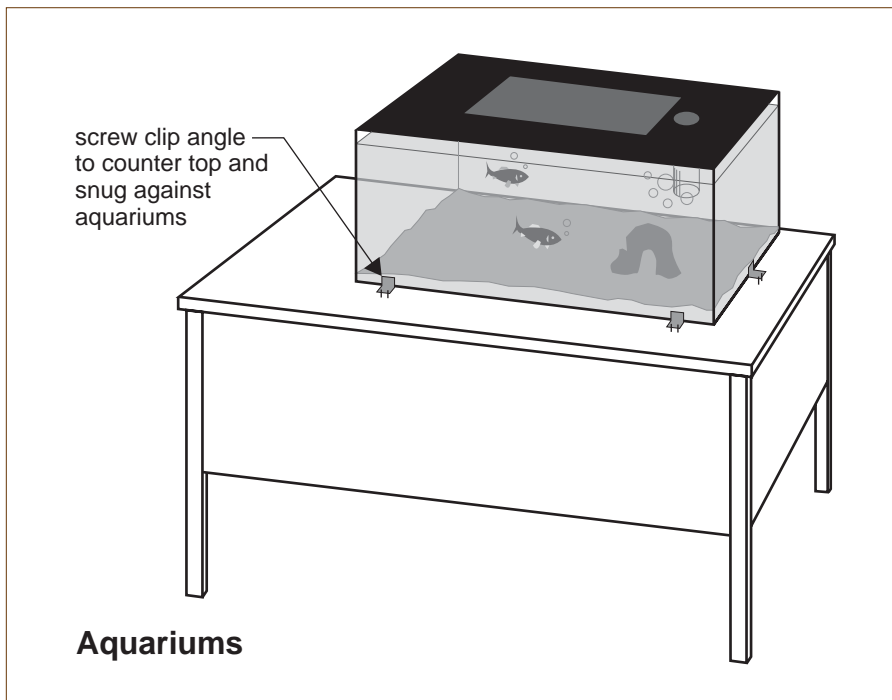

Hazards

- Unsecured aquariums may fall,
- striking nearby occupants,
 - blocking exit ways during an emergency, or
 - flooding adjacent spaces.

Recommendations

- Fasten clip angle to tabletop against each side of the aquarium.

Notes

- Locate aquarium away from doors and exit ways.

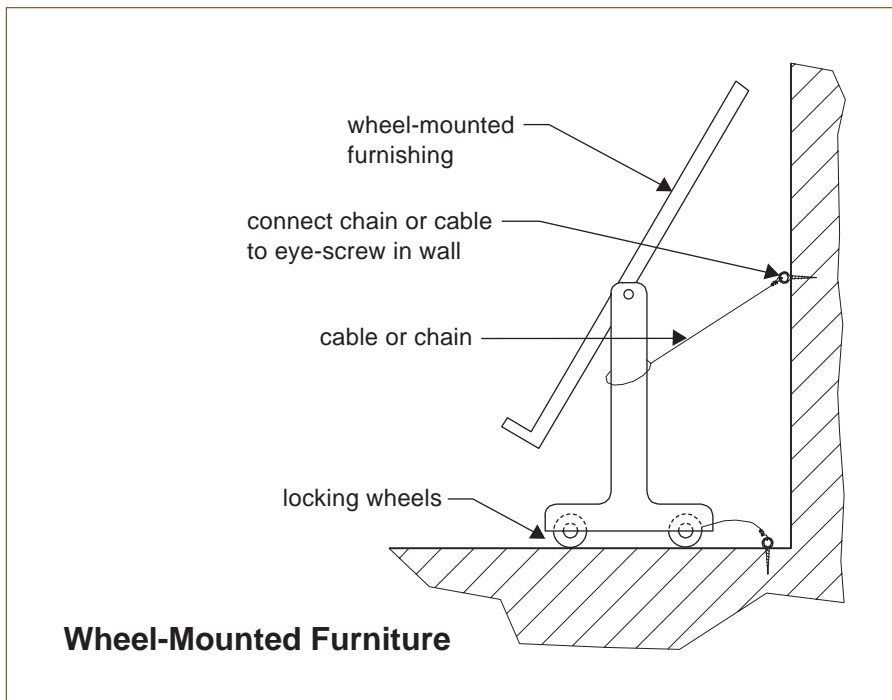

Hazards

- Unsecured wheel-mounted furniture may roll or fall, striking nearby occupants or blocking doors and exit ways for evacuation during an emergency.

Recommendations

- Install eyescrews to wall and secure furniture to eyescrews with cable, chain or rope.
- Replace free rolling wheels with lockable wheels.
- If wheels are not lockable, install eyescrews to floor and secure furniture to eyescrews with cable, chain or rope.

Notes

- Eyescrews must be installed into wall studs or blocking.

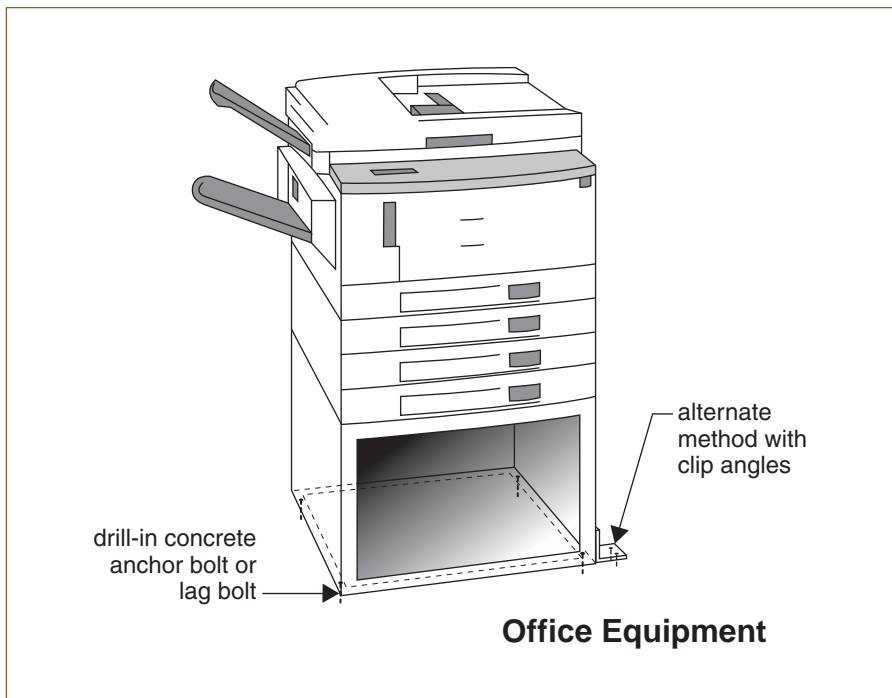

Hazards

- Unsecured office equipment may fall, injuring nearby occupants.
- Fallen office equipment may damage electrical wiring, exposing occupants to electrical shock, or starting a fire.

Recommendations

- Secure office equipment to floor.

Notes

- Use concrete drill-in anchor bolts for concrete floor.
- Use lag bolts for wood floor. Lag bolts must be installed into floor beams or blocking.
- Bolts must be installed through metal framing of office equipment. Do not install through thin gauge housing panels.
- If clip angles are used, attach clip angles to metal framing of the equipment. Do not attach to thin gauge housing panels.

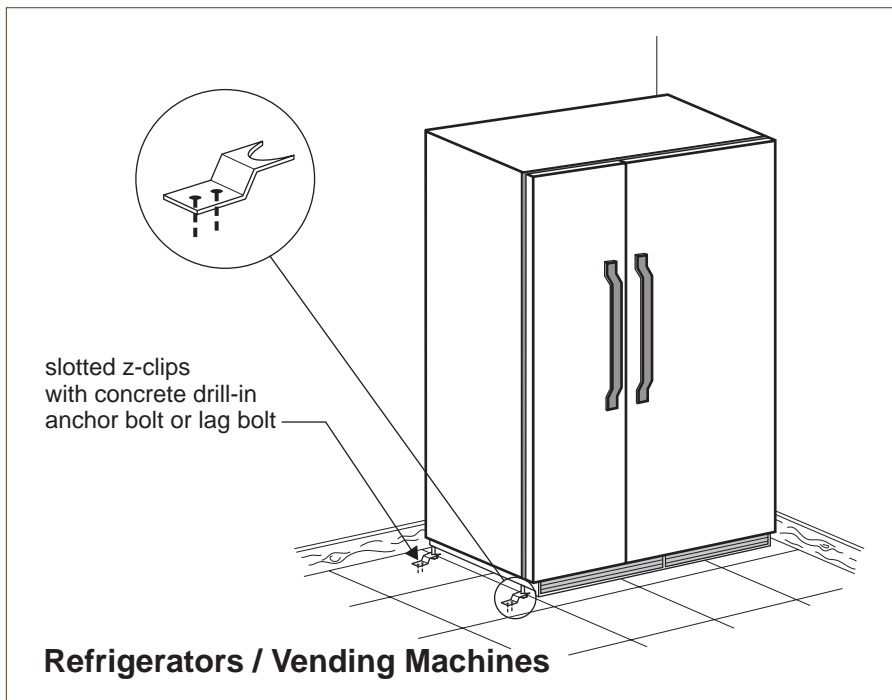
**Hazards**

Unsecured refrigerator or vending machines may slide or tip,

- striking nearby occupants,
- blocking doors and exit ways,
- interrupting utility services, or
- causing gas leak, fire, etc.

Recommendations

- Secure refrigerator or vending machines to floor with slotted z-clips or clip angle.

Notes

- Slotted z-clip must have minimum of two bolts to the floor.
- Relocate refrigerator or vending machines away from doors and exit ways.

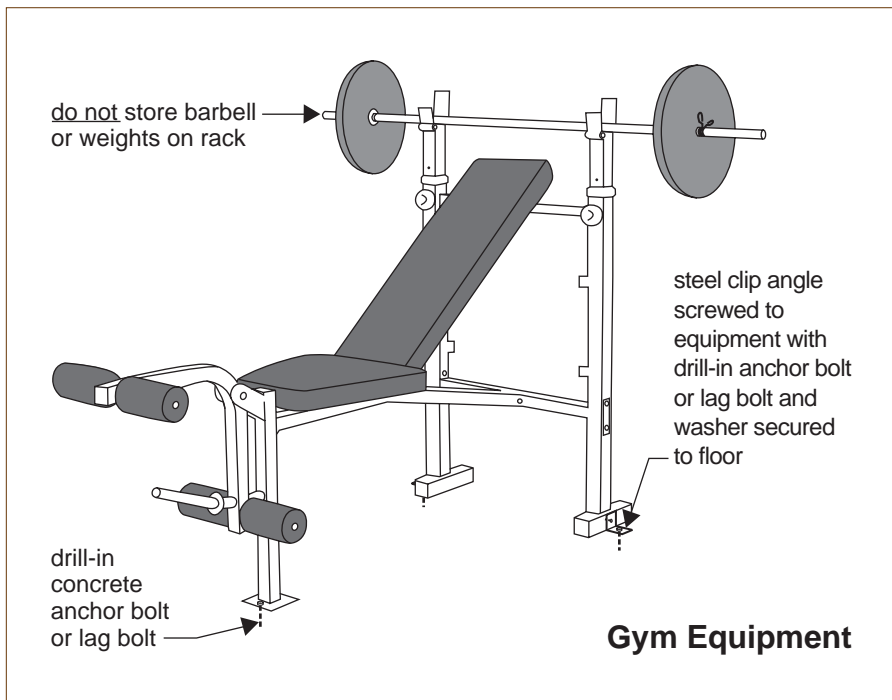

Hazards

- Unsecured shop/ gym equipment may fall, injuring nearby occupants, or blocking doors or exit ways for evacuation during an emergency.

Recommendations

- Secure equipment to concrete floor with concrete drill-in anchor bolt at each leg.
- Secure equipment to wood floor with lag bolt at each leg. Lag bolt must be installed into floor joists or blocking.
- When clip angle is required, screw clip angle to equipment and fasten to floor with either concrete drill-in anchor or lag bolts.

Notes

- Do not store weights or barbells on press bench. Store weights in weight rack that is secured to the floor.

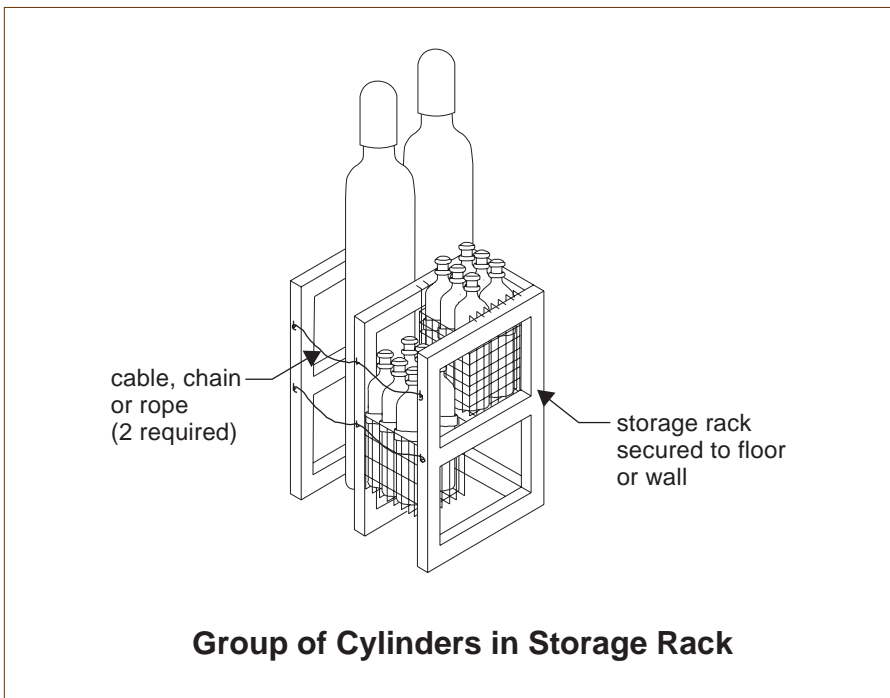
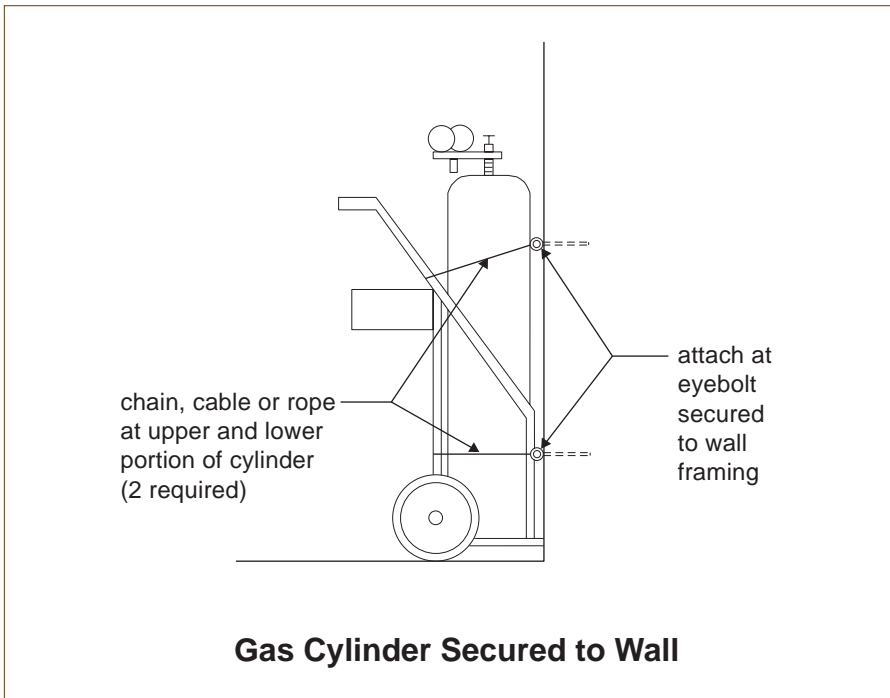

Hazards

- Unsecured cylinders or tanks may fall over and damage the shut-off valve, releasing hazardous or flammable contents.
- A tank with a damaged shut-off valve may result in the tank or valve becoming a projectile.
- Unsecured cylinders may fall over, striking or rolling and striking nearby occupants.

Recommendations

- Secure each cylinder or tank to a wall with two restraints (one restraint at the upper and the other at the lower portion of the cylinder).
- Alternatively to providing wall restraints, cylinders or tanks may be kept within a storage rack or compartment that is secured to a wall or floor.
- Store gas cylinders or tanks in non-occupied areas, and away from exit routes or exit doors.

Notes

- Chain, cable or rope restraints must be attached to eyebolts or other closed hook structural fasteners.
- Eyebolts or other fasteners must be attached to wall framing (studs or blocking.)

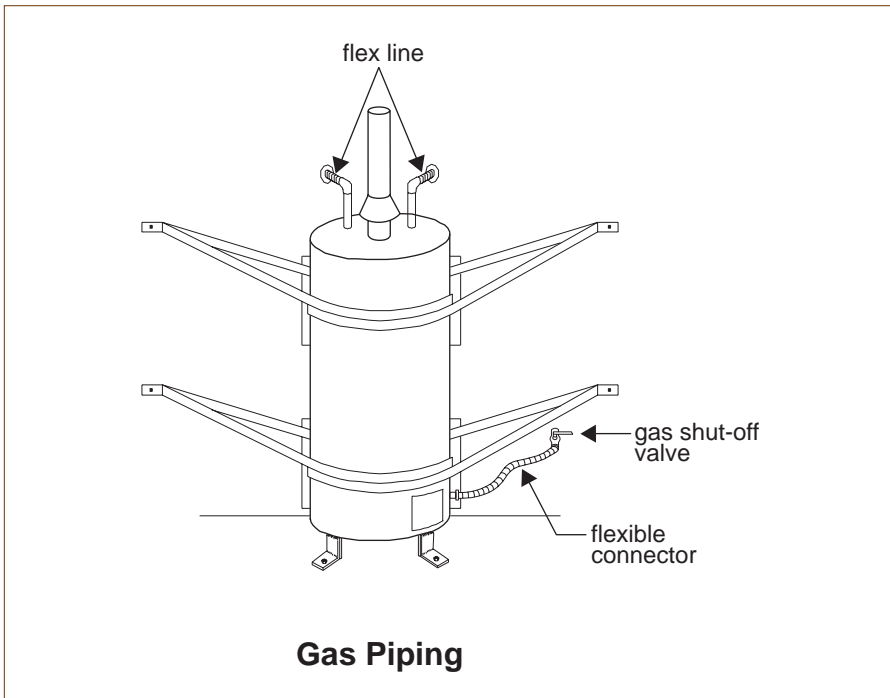

Hazards

- Gas piping may break, causing gas leaks that can harm nearby occupants, or starting a fire.

Recommendations

- Install flexible piping when connecting to mechanical equipment such as water heater.
- Install seismic - actuated gas shutoff valve or excess flow gas shutoff valve.

Notes

- Mechanical equipment must also be anchored.

Resources

- <http://www.dsa.dgs.ca.gov/>

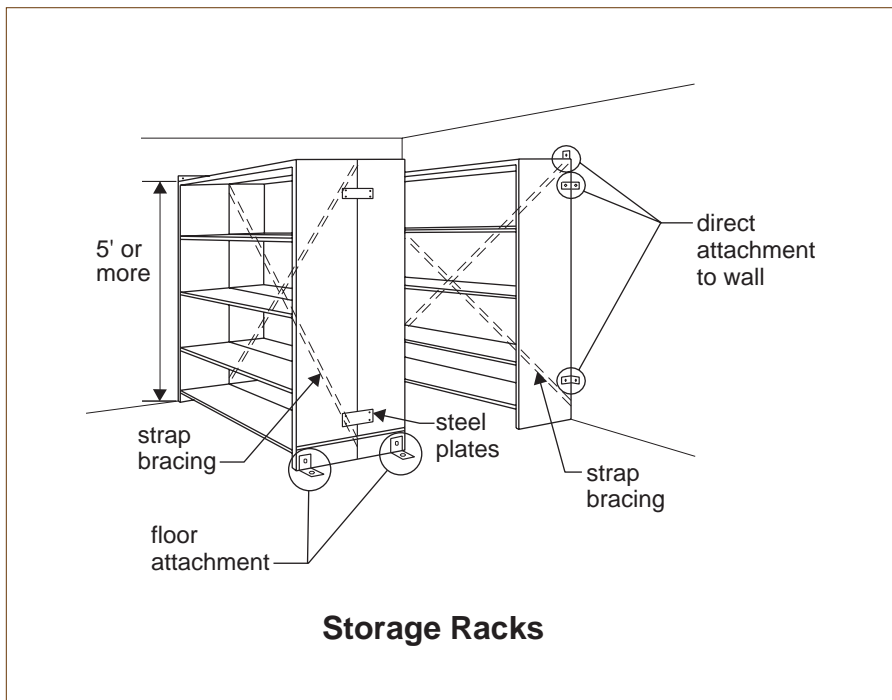

Hazards

- Unsecured storage racks may fall, striking nearby occupants or blocking doors and exit ways for evacuation during an emergency.

Recommendations

- Secure with clip angles, bolts, or screws to floor.
- Strengthen with x-straps on backside.

Notes

- Fasteners should be installed into framing of storage racks.
- Locate heavy items to low level shelves.
- Consult a qualified architect or structural engineer for seismic bracing requirements.

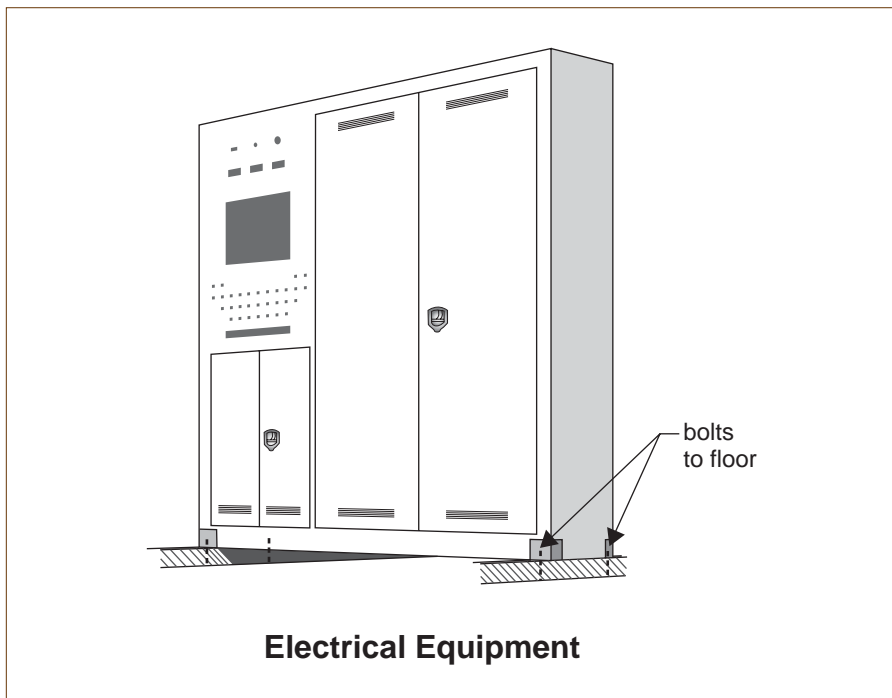

Hazards

Unsecured electrical equipment may slide or fall,

- interrupting vital utility services in an emergency,
- injuring nearby occupants, or
- damaging electrical wiring that would cause electrical shocks or fires.

Recommendations

- Secure electrical equipment to floor.
- Provide flexible cable connection to equipment.

Notes

- Consult a qualified architect or professional engineer for seismic anchorage requirements.
- Use concrete drill-in anchor bolts for concrete floor.
- Use lag bolts for wood floor. Lag bolts must be installed into floor beams or blocking.
- Bolts must be installed through metal framing of electrical equipment. Do not install through thin gauge housing panels.
- If clip angles were used, attach clip angles to metal framing of the equipment. Do not attach to thin gauge housing panels.

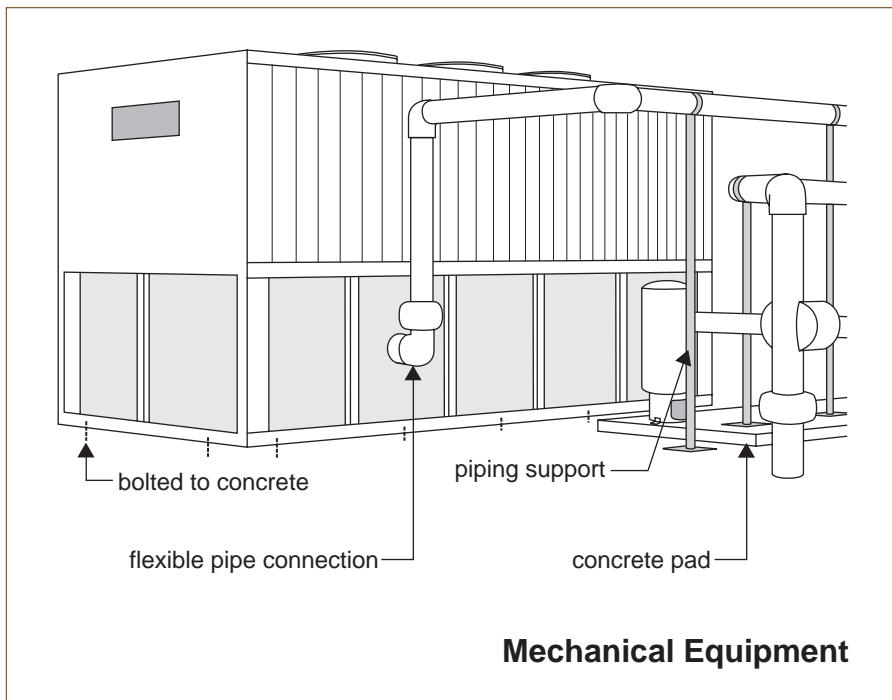

Hazards

- Unsecured mechanical equipment may slide or fall,
- striking occupants nearby,
 - damaging electrical wiring, water lines, or gas lines.
 - causing interruption to vital utility services,
 - exposing nearby occupants to electrical shocks, or
 - starting a fire.

Recommendations

- Secure mechanical equipment to roof. Clip angles may be used.

Notes

- Mechanical equipment must have flexible conduits or pipes.
- Consult a qualified architect or professional engineer for seismic anchorage requirements.
- When vibration isolation is required, consider using vibration isolators that are pre-approved by the Office of Statewide Health Planning and Development (OSHPD).

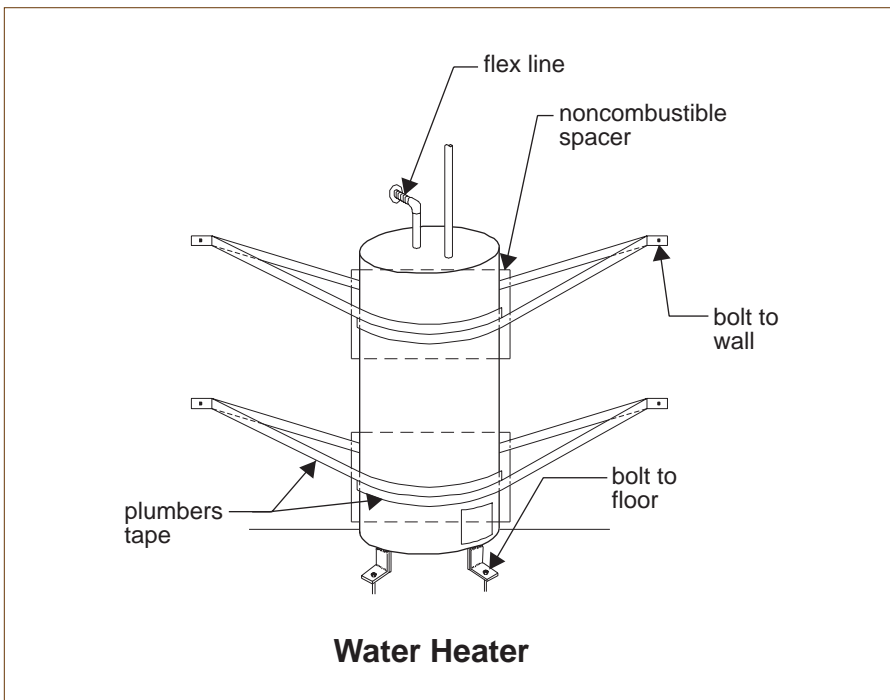

Hazards

Unsecured plumbing equipment such as a water heater may slide or fall,

- striking nearby occupants,
- spilling hot water on floor or nearby occupants, or
- rupturing gas lines.

Recommendations

- Secure base of water heater by bolting to floor, and
- Secure water heater to wall with plumber’s tapes, or other methods recommended by the Department of General Services – Division of the State Architect (DSA).
- See “Resources” below for more information.

Notes

- Use concrete drill-in anchor bolts for concrete floor, and wall.
- Use lag bolts for wood floor and wall. Lag bolts must be installed into floor beams, wall studs, or blocking.
- Space between wall and water heater must be shimmed tight with non-combustible at the locations of the plumber’s tape.
- Consult a qualified architect or professional engineer for seismic anchorage requirements.

Resources

- www.documents.dgs.ca.gov/dsa/pubs/waterheaterbracing01.31.02
“Guidelines for Earthquake Bracing of Residential Water Heaters.”

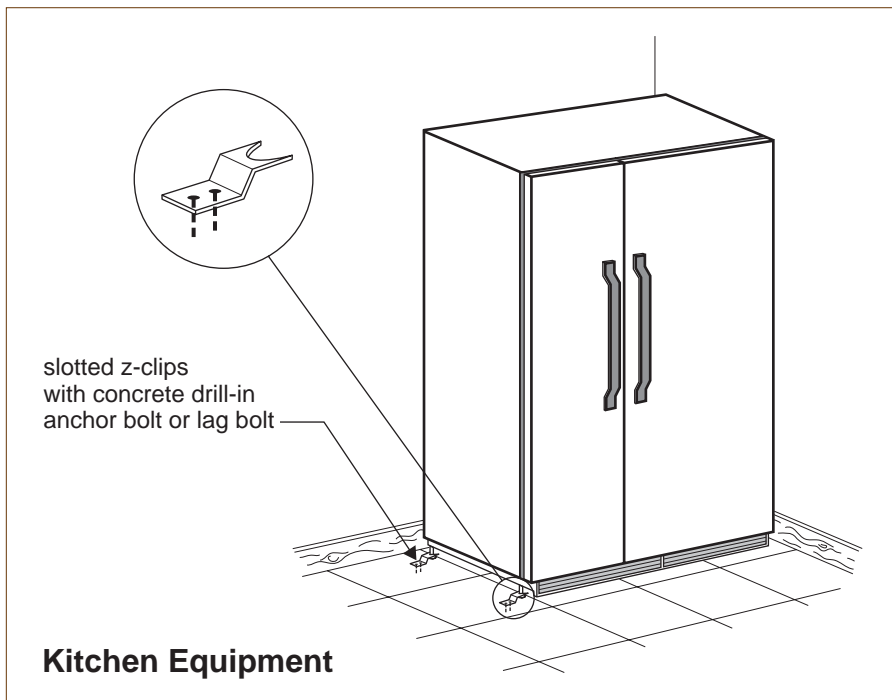

Hazards

Unsecured kitchen equipments may fall,

- striking nearby occupants,
- blocking doors and exit ways for evacuation during an emergency,
- interrupting utility services, or causing gas leak, fire, etc.

Recommendations

- Secure kitchen equipments to floor with slotted z-clips or clip angle.

Notes

- Slotted z-clip must have minimum of two bolts to the floor.
- Relocate kitchen equipments away from doors and exit ways.

Resources

- Kitchen Ventilation Systems & Food Service Equipment Guidelines.
- Consult a qualified architect or professional engineer for seismic anchorage requirements.

Resources / References

- “Seismic Design Criteria of Non-structural Systems for New School Facilities And Existing School Facilities”, Salt Lake City School District, April 30, 2001.
<http://edfacilities.org/rl/disaster.cfm>
- “School Facilities Manual – Non-structural Protection Guide”, Office of State Superintendent of Public Instruction and Seattle Public Schools, 2nd Edition, October, 1999.
<http://www.cityofseattle.net/projectimpact/pdfs/Guide%20-%20Section%20A.pdf>
- “Reducing Risks of Non-structural Earthquake Damage”, FEMA 074
- “Seismic Restraint Manual Guidelines for Mechanical Systems;” Sheet Metal and Air-Conditioning Contractors’ national Association, Inc. (SMACNA); 2nd Edition; 1998.
- □ “Addendum to Seismic Restraint Guidelines for Mechanical Systems;” Sheet Metal and Air-Conditioning Contractors’ national Association, Inc. (SMACNA); September, 2002.
- “Kitchen Ventilation Systems & Food Service Equipment Guidelines;” Sheet Metal and Air-Conditioning Contractors’ national Association, Inc. (SMACNA); Section II, Appendix A; 2001
<http://www.SMACNA.org>
- “Guidelines for Earthquake Bracing of Residential Water Heaters”,
<http://www.documents.dgs.ca.gov/dsa/pubs/waterheaterbracing01.31.02.pdf>
- Gas Shutoff Valves, http://www.dsa.ca.gov/gas_shutoff.htm

EARTHQUAKE HAZARDS CHECKLIST

SCHOOL NAME:	INVENTORY DATE:
BUILDING NAME / ID:	INVENTORY BY:
ROOM NAME / ID:	

		ITEM PRESENT?		ITEM COMPLIES?		NOTES
1 CEILING AND OVERHEAD	PAGE	YES	NO	YES	NO	
• light fixtures - hanging / pendant	7	<input type="checkbox"/>	<input type="checkbox"/>	<input type="checkbox"/>	<input type="checkbox"/>	
• recessed lights fixtures at suspended ceiling	8	<input type="checkbox"/>	<input type="checkbox"/>	<input type="checkbox"/>	<input type="checkbox"/>	
• recessed HVAC registers at suspended ceiling	8	<input type="checkbox"/>	<input type="checkbox"/>	<input type="checkbox"/>	<input type="checkbox"/>	
• suspended ceiling (metal grid lay-in acoustical panels)	9	<input type="checkbox"/>	<input type="checkbox"/>	<input type="checkbox"/>	<input type="checkbox"/>	
• hanging displays and plants	10	<input type="checkbox"/>	<input type="checkbox"/>	<input type="checkbox"/>	<input type="checkbox"/>	
• suspended space heaters / AC units	11	<input type="checkbox"/>	<input type="checkbox"/>	<input type="checkbox"/>	<input type="checkbox"/>	
• decorative ceiling / lattice work	12	<input type="checkbox"/>	<input type="checkbox"/>	<input type="checkbox"/>	<input type="checkbox"/>	
• conduit / piping	13	<input type="checkbox"/>	<input type="checkbox"/>	<input type="checkbox"/>	<input type="checkbox"/>	
• ductwork	14	<input type="checkbox"/>	<input type="checkbox"/>	<input type="checkbox"/>	<input type="checkbox"/>	
• lath / plaster soffits (exterior)	15	<input type="checkbox"/>	<input type="checkbox"/>	<input type="checkbox"/>	<input type="checkbox"/>	
• tile roofing (exterior)	16	<input type="checkbox"/>	<input type="checkbox"/>	<input type="checkbox"/>	<input type="checkbox"/>	
• unreinforced masonry chimney (exterior)	17	<input type="checkbox"/>	<input type="checkbox"/>	<input type="checkbox"/>	<input type="checkbox"/>	
2 WALL - MOUNTED ITEMS	PAGE					
• shelving	21	<input type="checkbox"/>	<input type="checkbox"/>	<input type="checkbox"/>	<input type="checkbox"/>	
• wall-mounted cabinets / lockers / coat closets	22	<input type="checkbox"/>	<input type="checkbox"/>	<input type="checkbox"/>	<input type="checkbox"/>	
• wall-mounted TV, video monitor or speakers	23	<input type="checkbox"/>	<input type="checkbox"/>	<input type="checkbox"/>	<input type="checkbox"/>	
• pictures / wall decorations / signs	24	<input type="checkbox"/>	<input type="checkbox"/>	<input type="checkbox"/>	<input type="checkbox"/>	
• fire extinguisher	25	<input type="checkbox"/>	<input type="checkbox"/>	<input type="checkbox"/>	<input type="checkbox"/>	
• interior walls	26	<input type="checkbox"/>	<input type="checkbox"/>	<input type="checkbox"/>	<input type="checkbox"/>	
• free-standing and cubicle partitions	27	<input type="checkbox"/>	<input type="checkbox"/>	<input type="checkbox"/>	<input type="checkbox"/>	
• windows	28	<input type="checkbox"/>	<input type="checkbox"/>	<input type="checkbox"/>	<input type="checkbox"/>	
3 FURNITURE & EQUIPMENT	PAGE					
• file cabinets	31	<input type="checkbox"/>	<input type="checkbox"/>	<input type="checkbox"/>	<input type="checkbox"/>	
• bookcases	32 / 33	<input type="checkbox"/>	<input type="checkbox"/>	<input type="checkbox"/>	<input type="checkbox"/>	
• desktop and countertop equipment	34	<input type="checkbox"/>	<input type="checkbox"/>	<input type="checkbox"/>	<input type="checkbox"/>	
• equipment on cart (video, projectors)	35	<input type="checkbox"/>	<input type="checkbox"/>	<input type="checkbox"/>	<input type="checkbox"/>	
• display cases / art objects / potted plants	36	<input type="checkbox"/>	<input type="checkbox"/>	<input type="checkbox"/>	<input type="checkbox"/>	
• aquariums	37	<input type="checkbox"/>	<input type="checkbox"/>	<input type="checkbox"/>	<input type="checkbox"/>	
• equipment on wheels / rollers (e.g. piano, chalkboard)	38	<input type="checkbox"/>	<input type="checkbox"/>	<input type="checkbox"/>	<input type="checkbox"/>	
• copy machines / printers	39	<input type="checkbox"/>	<input type="checkbox"/>	<input type="checkbox"/>	<input type="checkbox"/>	
• refrigerators / vending machines	40	<input type="checkbox"/>	<input type="checkbox"/>	<input type="checkbox"/>	<input type="checkbox"/>	
• shop and gym equipment	41	<input type="checkbox"/>	<input type="checkbox"/>	<input type="checkbox"/>	<input type="checkbox"/>	
• gas cylinders	42	<input type="checkbox"/>	<input type="checkbox"/>	<input type="checkbox"/>	<input type="checkbox"/>	
• gas piping (shut-off valve / flex connector)	43	<input type="checkbox"/>	<input type="checkbox"/>	<input type="checkbox"/>	<input type="checkbox"/>	
• storage racks	44	<input type="checkbox"/>	<input type="checkbox"/>	<input type="checkbox"/>	<input type="checkbox"/>	
• electrical equipment (cabinets, switch gear, transformers)	45	<input type="checkbox"/>	<input type="checkbox"/>	<input type="checkbox"/>	<input type="checkbox"/>	
• mechanical equipment (chillers, fans)	46	<input type="checkbox"/>	<input type="checkbox"/>	<input type="checkbox"/>	<input type="checkbox"/>	
• plumbing equipment (water heater, tanks, pumps)	47	<input type="checkbox"/>	<input type="checkbox"/>	<input type="checkbox"/>	<input type="checkbox"/>	
• kitchen equipment (oven, range, hood, refrigerator / freezer, dishwasher)	48	<input type="checkbox"/>	<input type="checkbox"/>	<input type="checkbox"/>	<input type="checkbox"/>	

